

LVA series of 4-Quadrant amplifiers

**AUTOMOTIVE SUPPLY SIMULATION
AT IT'S BEST**



LVA 1000 Front panel

- ✓ Extremely low harmonic distortion - even under very non-linear load conditions
- ✓ Very fast slew rate > 20V/μs
- ✓ Operates from DC up to 50kHz large signal bandwidth (-3dB)
- ✓ Small signal bandwidth up to 300kHz
- ✓ High short-term overload characteristic (for 30s)
- ✓ Very high peak-load ability (up to 200ms)
- ✓ Programmable internal resistance 0 ... 200 mΩ
- ✓ Sink operation mode included – real 4-quadrant operation mode to be disabled through the touch panel menu
- ✓ Unsymmetric or symmetric voltage ranges
- ✓ Touch panel operation 7" 800x480

The relating standards:

*ISO 7637-2
 ISO 16750-2
 ISO 21848
 LV 124
 VDA 320 (LV 148)
 SAE J 1113-11
 BMW GS 95002
 BMW GS 95003-2
 BMW GS 95024-2-2
 BMW GS 95026
 Ford FMC 1278
 General Motors GMW 3097
 JLR-EMC-CSv1.04A
 Mercedes-Benz LV 124-1
 Mercedes-Benz LV 148
 MIL-STD-461F
 MIL-STD-704F
 MIL-STD-1275E
 Mitsubishi ES-X82115
 Nissan 28400NDS02_3
 PSA B21 7110
 Renault 36-00-808/--M
 VW 80000
 VW 82148
 VW TL 81000*

**THE REFERENCE SOURCE FOR AUTOMOTIVE APPLICATIONS
PERFECT FOR MANY AVIONIC AND MILITARY STANDARDS**

AMPLIFIER RANGES – FRONT PANEL MENUS AND OPTIONS

The LVA Amplifier offers four standard voltage ranges:

20V_{DC}

36V_{DC}

54V_{DC}

70V_{DC}

Depending on the amplifier's output stage structure, the voltage ranges can be symmetric or asymmetric.

The built in oscillator unit supplies several standard functions:

DC signal, Sine wave

Rectangular wave

Triangular wave

Ramp (amplitude sweep)

User defined

Alternatively, an external signal generator can be used.

For each voltage range the operating mode options can be selected.

With the option "OPD" (over-voltage protection device) the EUT's supply voltage is monitored and the EUT is protected against very fast rising high voltage.

The LVA allows optionally specifying the amplifier's internal resistance from 0 to 200mΩ in each mode of operation.

Optionally the sink mode capability can be disabled.

A built-in measurement unit displays the relevant measurement values.

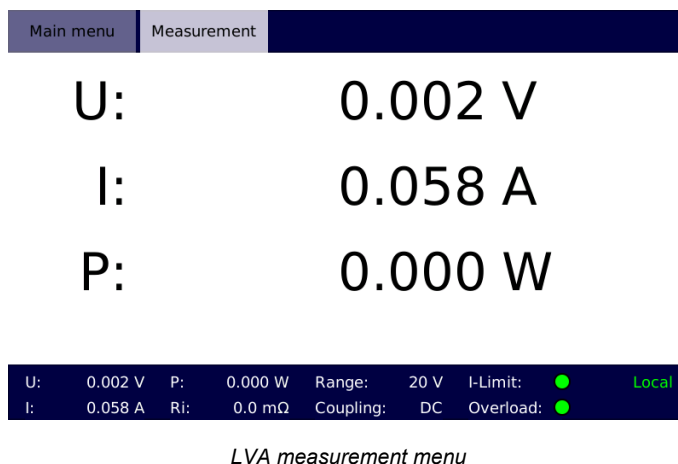
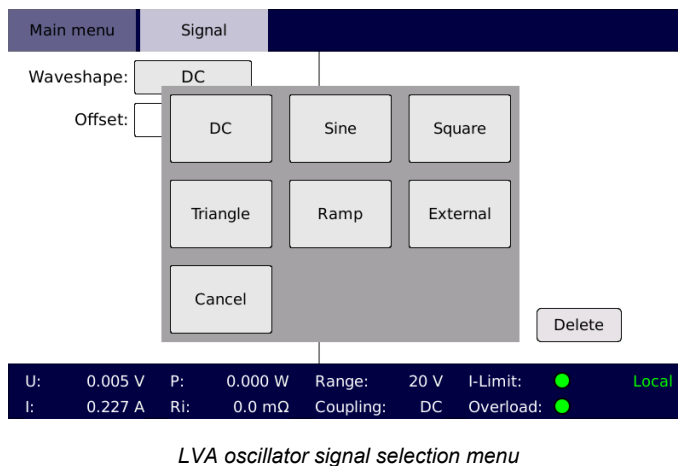
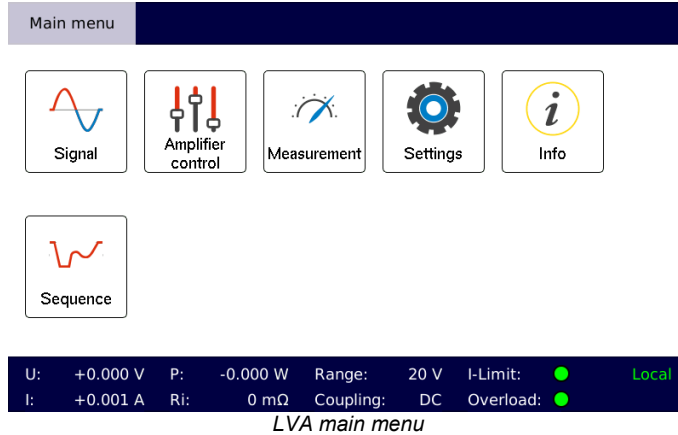

AMPLIFIER CHARACTERISTIC – 4-QUADRANT OPERATION

The LVA amplifier is a real 4-Quadrant Amplifier.

Due to this advanced technology four different application scenarios are possible:

Example values 20V Range:

-U/+I

II. Quadrant

negative voltage, positive current

LVA 2500 example values:

U _{test}	I _{sink cont}	I _{sink short}
-12V	49A _{DC}	99A _{DC}

Typical application:

The LVA simulates a voltage drop of the negative testing voltage and the EUT's input has a capacitive stage feeding energy back into the LVA

+U/+I

I. Quadrant

positive voltage, positive current

LVA 2500 example values:

U _{test}	I _{cont}	I _{short}
12V	105A _{DC}	200A _{DC}

Typical application:

The LVA supplies positive testing voltage to the EUT

III. Quadrant

negative voltage, negative current

LVA 2500 example values:

U _{test}	I _{cont}	I _{short}
-12V	-65A _{DC}	-100A _{DC}

Typical application:

The LVA supplies negative testing voltage to the EUT

IV. Quadrant

positive voltage, negative current

LVA 2500 example values:

U _{test}	I _{sink cont}	I _{sink short}
12V	-65A _{DC}	-100A _{DC}

Typical application:

The LVA simulates a voltage drop and the EUT's input has a capacitive stage feeding energy back into the LVA

-U/-I

+U/-I

UNSYMMETRIC AMPLIFIER CHARACTERISTIC – OUTPUT POWER CAPABILITY
20V Range continuous power P_{cont} : LVA1000 - LVA2500 – LVA5000 – LVA7500

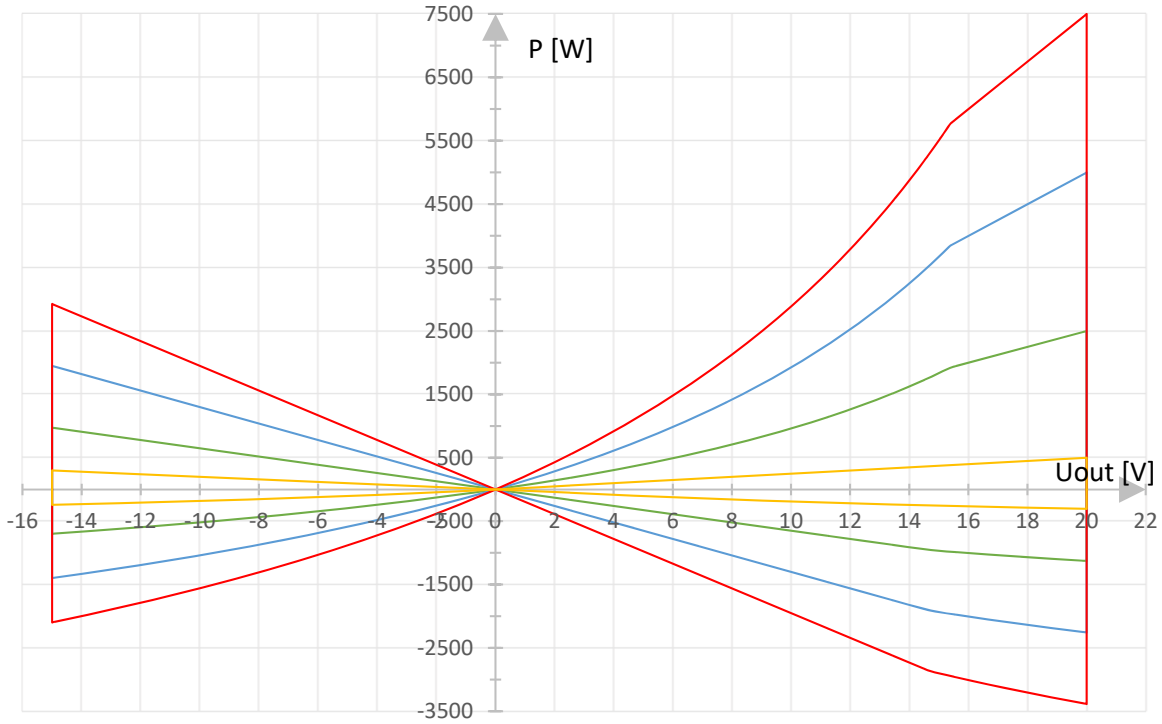

36V Range continuous power P_{cont} : LVA1000 - LVA2500 – LVA5000 – LVA7500

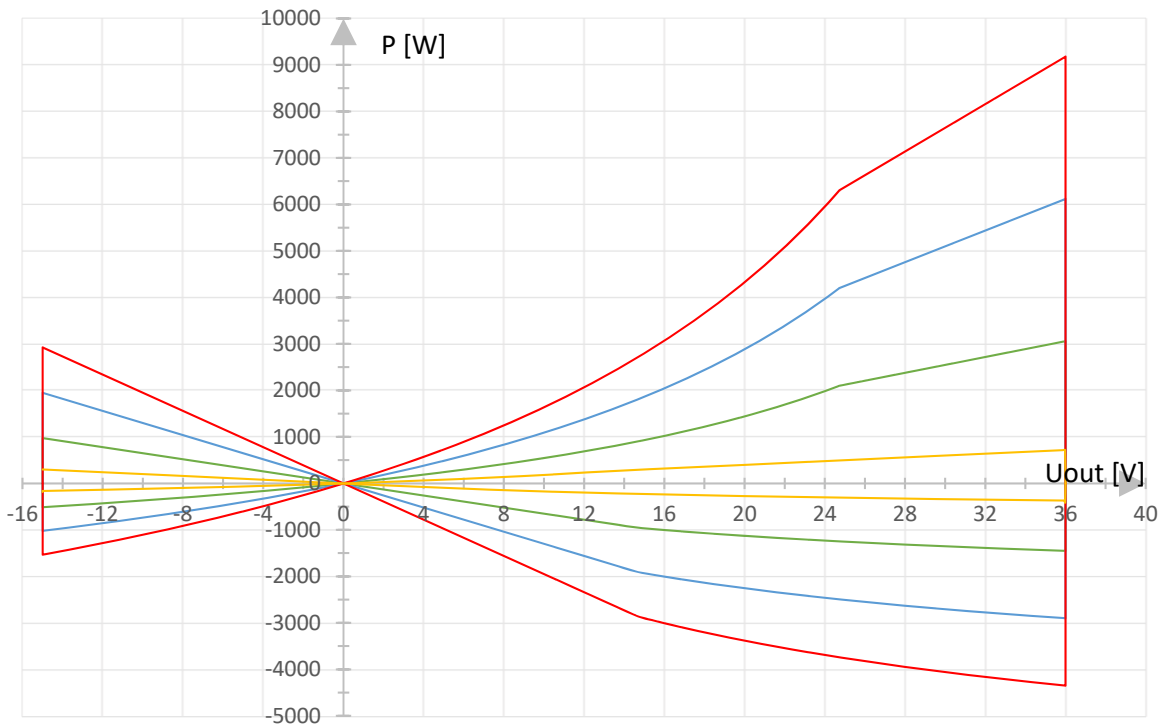

UNSYMMETRIC AMPLIFIER CHARACTERISTIC – OUTPUT POWER CAPABILITY
54V Range continuous power P_{cont} : LVA1000 - LVA2500 – LVA5000 – LVA7500

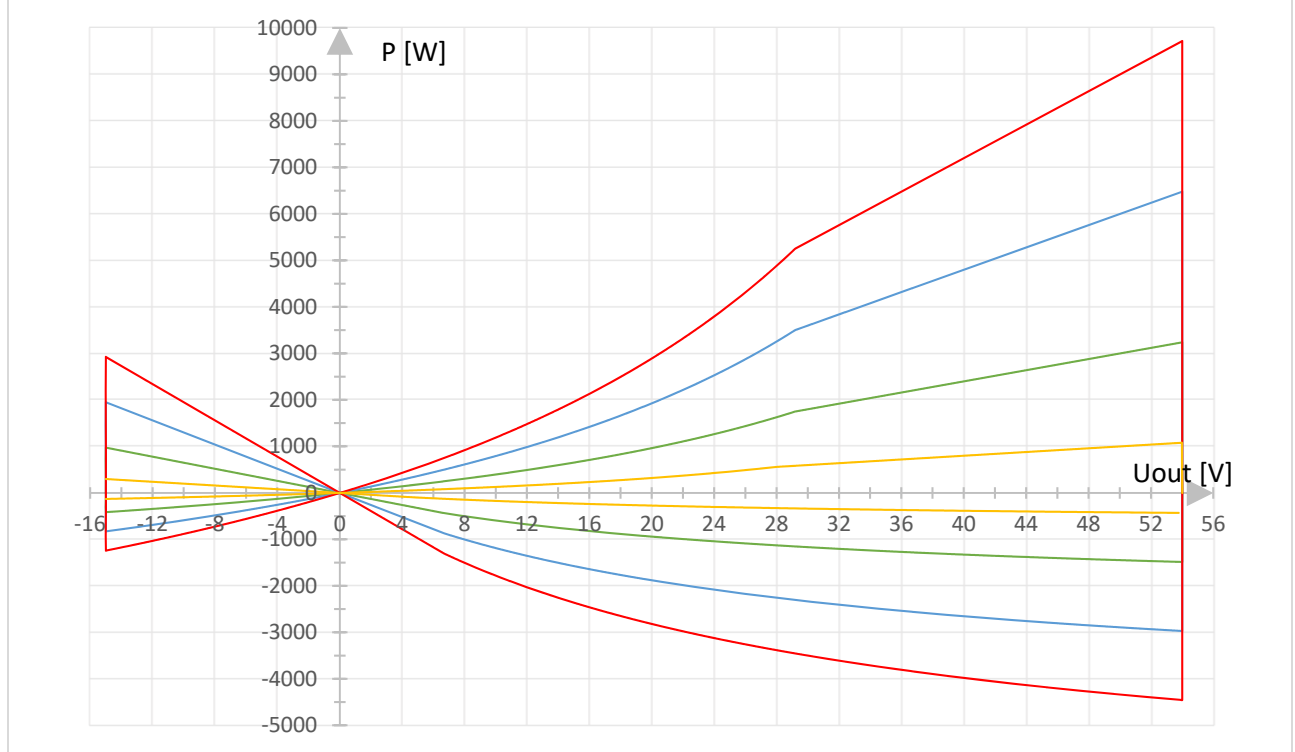

70V Range continuous power P_{cont} : LVA1000 - LVA2500 – LVA5000 – LVA7500

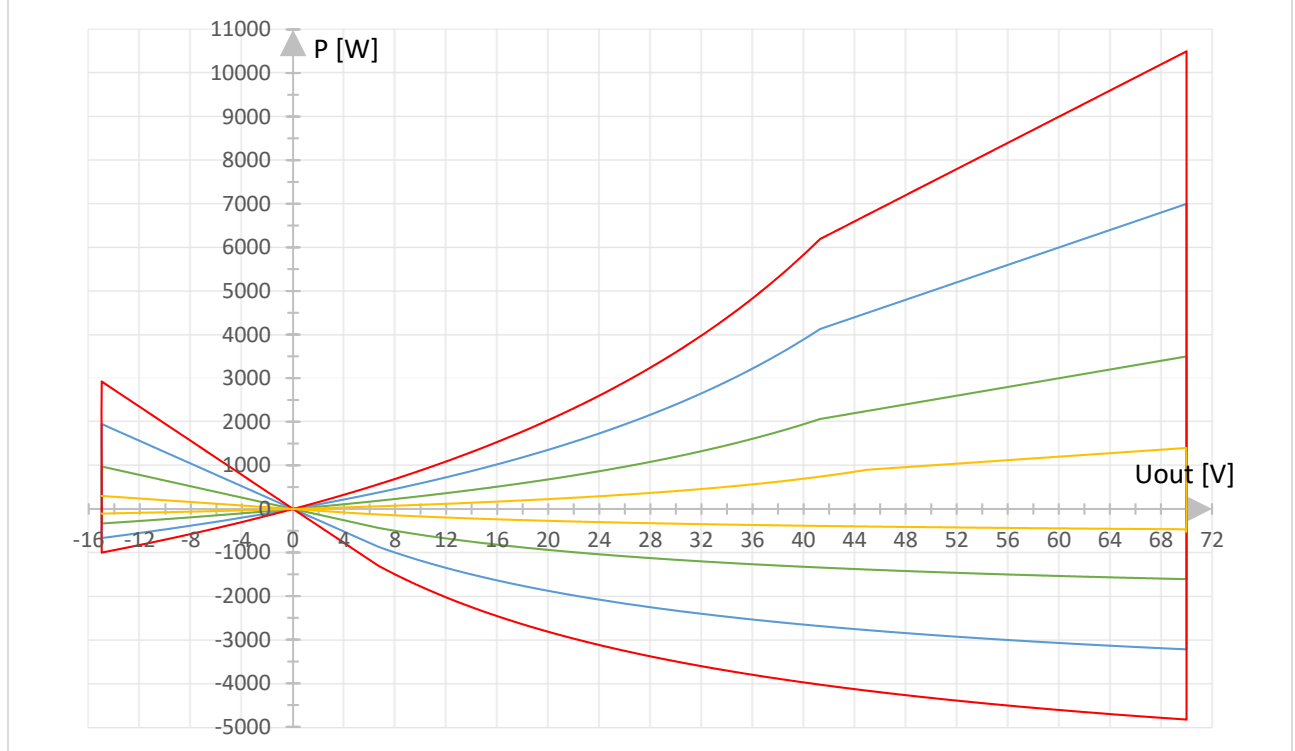

UNSYMMETRIC AMPLIFIER CHARACTERISTIC – OUTPUT CURRENT CAPABILITY
20V Range continuous current I_{cont} : LVA1000 - LVA2500 – LVA5000 – LVA7500

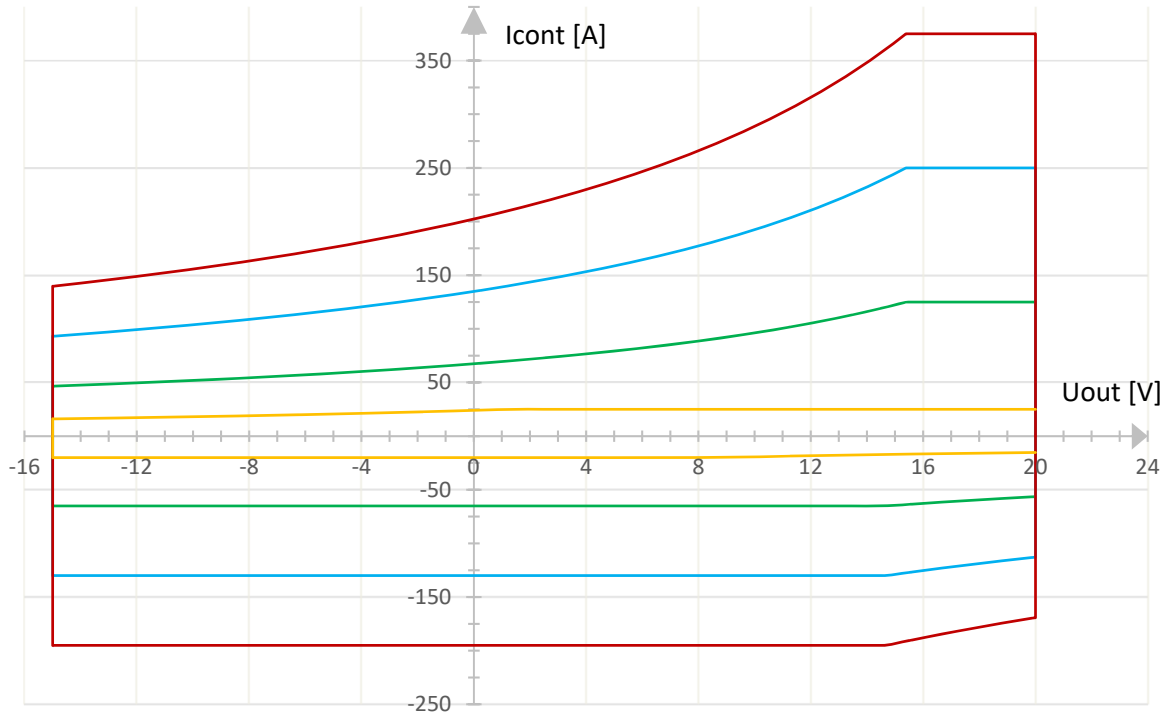

20V Range short-time current I_{short} : LVA1000 - LVA2500 – LVA5000 – LVA7500

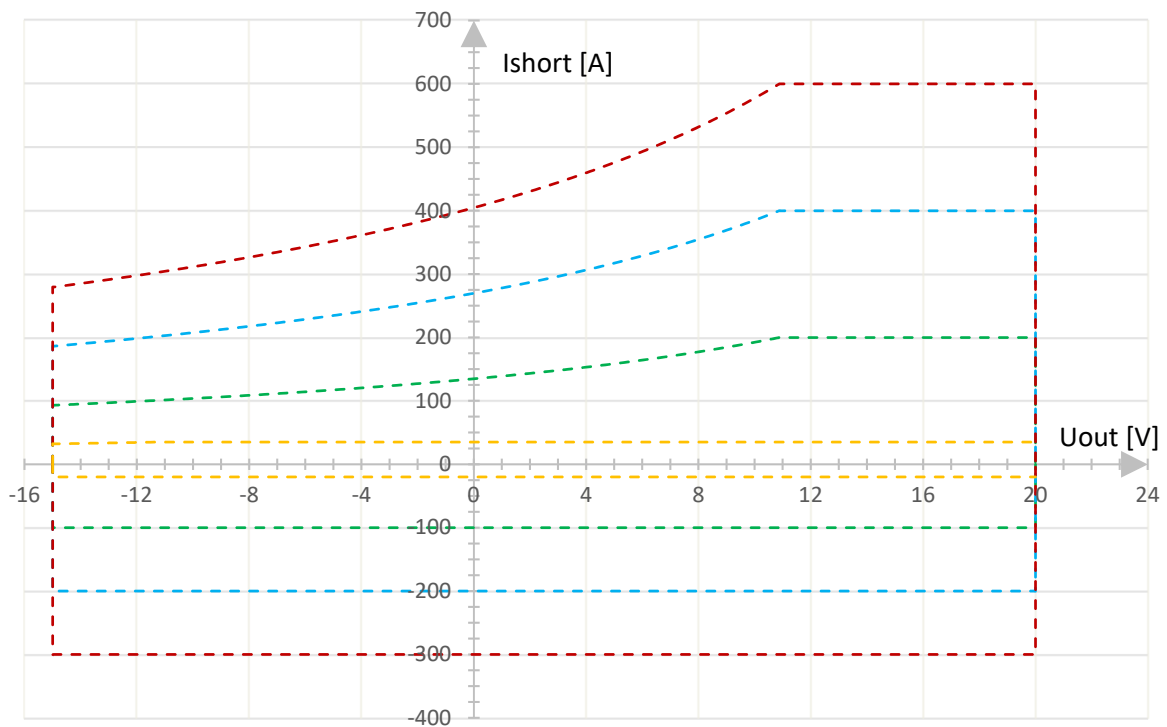

SYMMETRIC AMPLIFIER CHARACTERISTIC – OUTPUT CURRENT CAPABILITY
20V Range continuous current I_{cont} : LVA2500 – LVA5000 – LVA7500

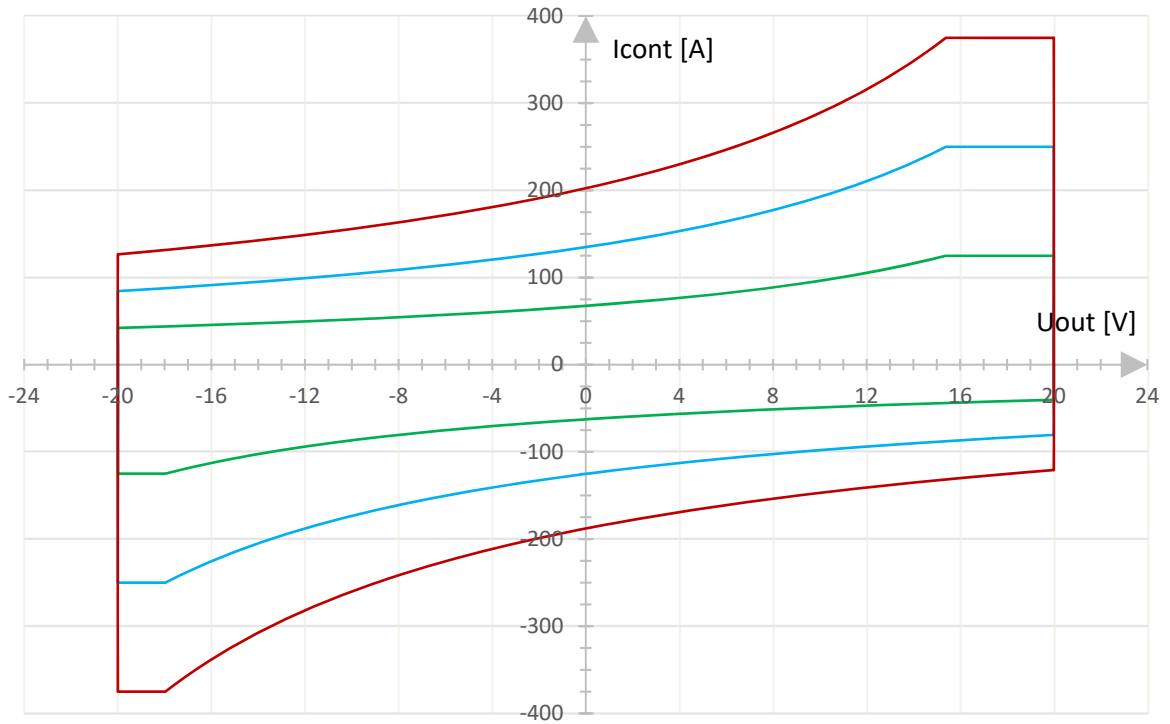

20V Range short-time current I_{short} : LVA2500 – LVA5000 – LVA7500

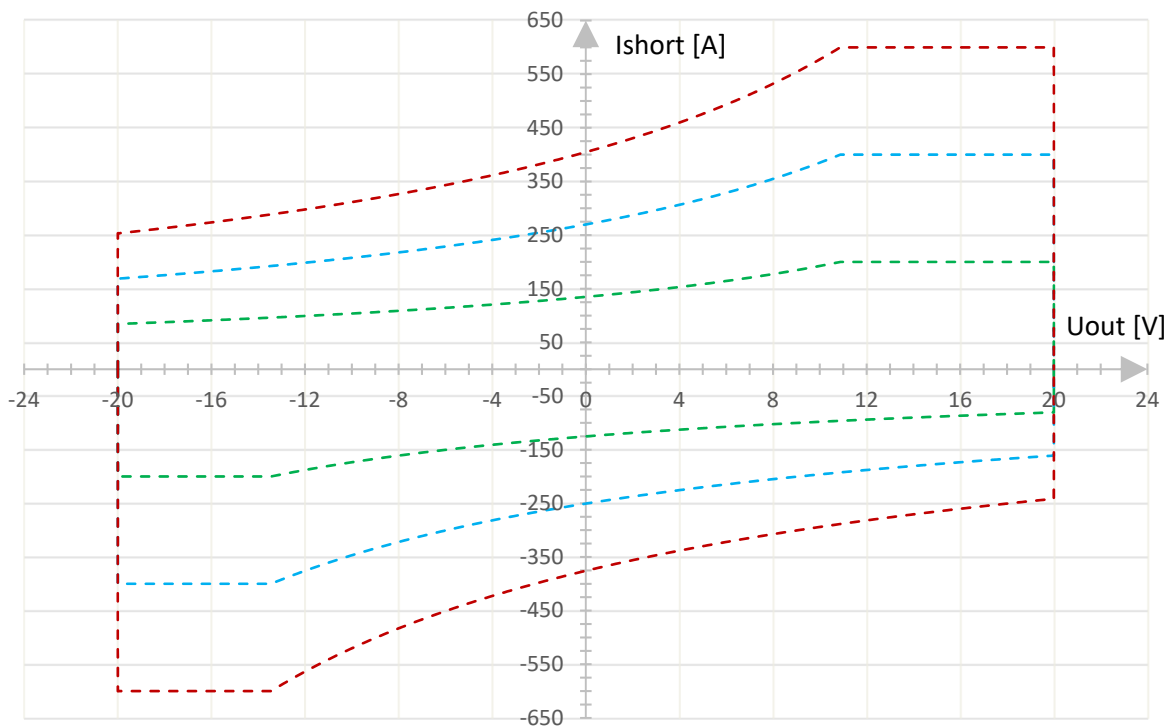

UNSYMMETRIC AMPLIFIER CHARACTERISTIC – OUTPUT CURRENT CAPABILITY
36V Range continuous current I_{cont} : LVA1000 - LVA2500 – LVA5000 – LVA7500

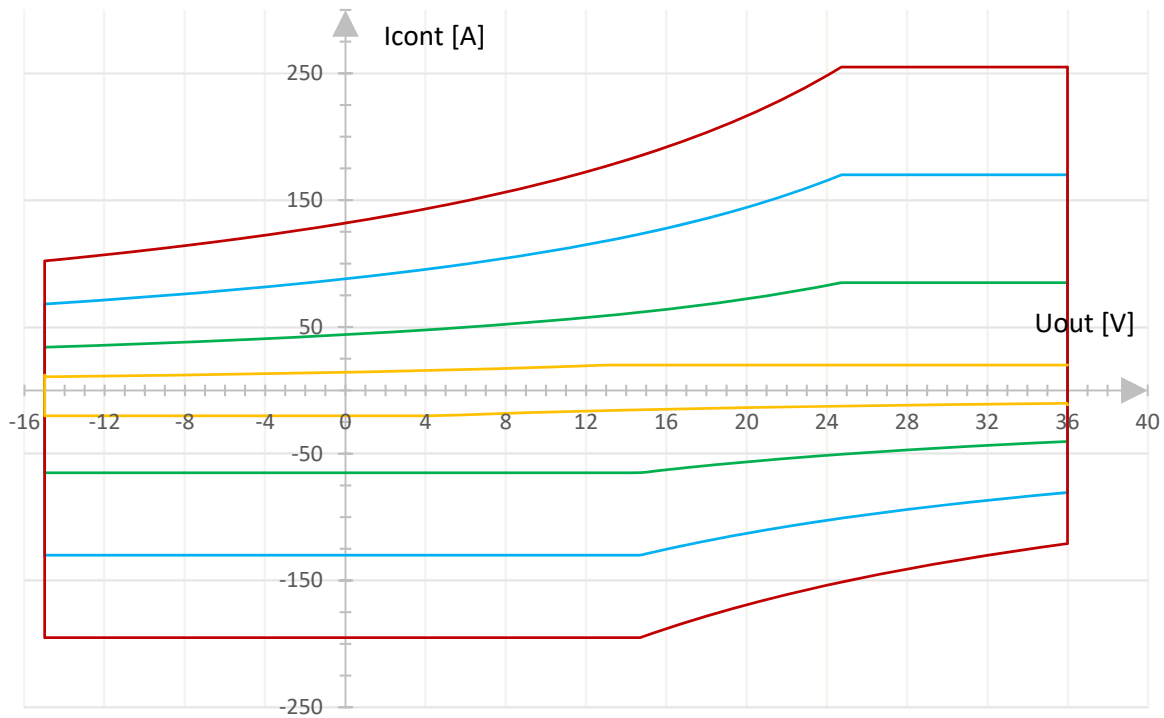

36V Range short-time current I_{short} : LVA1000 - LVA2500 – LVA5000 – LVA7500

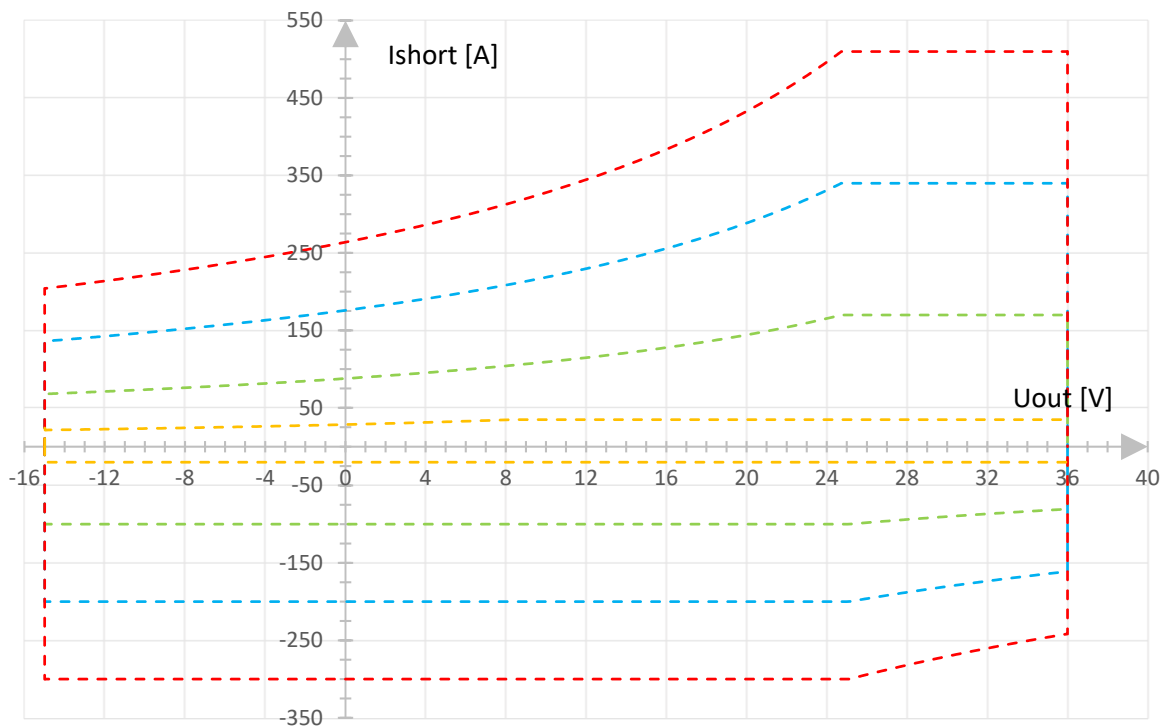

SYMMETRIC AMPLIFIER CHARACTERISTIC – OUTPUT CURRENT CAPABILITY
36V Range continuous current I_{cont} : LVA2500 – LVA5000 – LVA7500

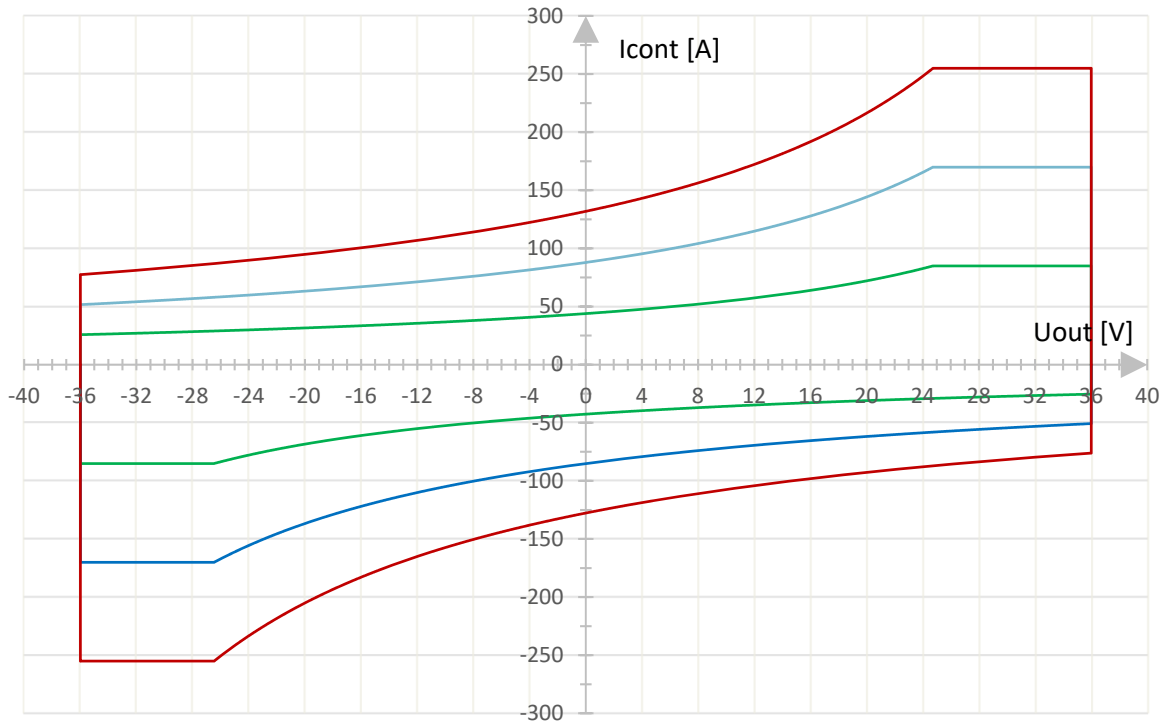

36V Range short-time current I_{short} : LVA2500 – LVA5000 – LVA7500

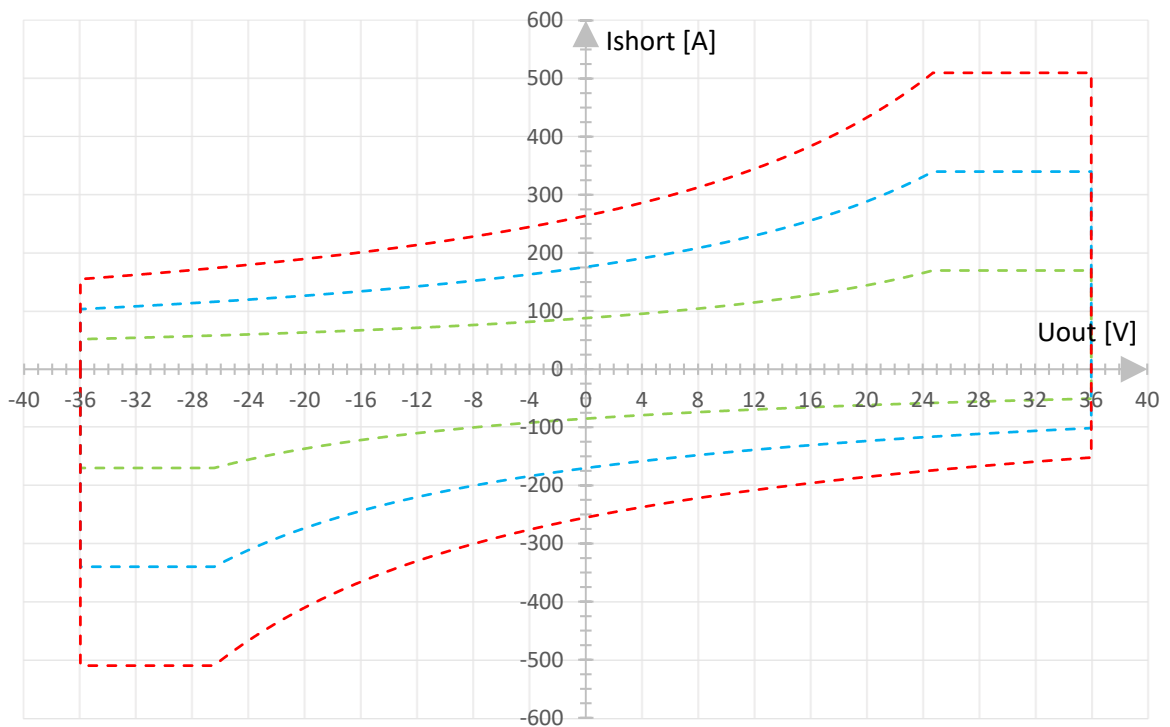

UNSYMMETRIC AMPLIFIER CHARACTERISTIC – OUTPUT CURRENT CAPABILITY
54V Range continuous current I_{cont} : LVA1000 - LVA2500 – LVA5000 – LVA7500

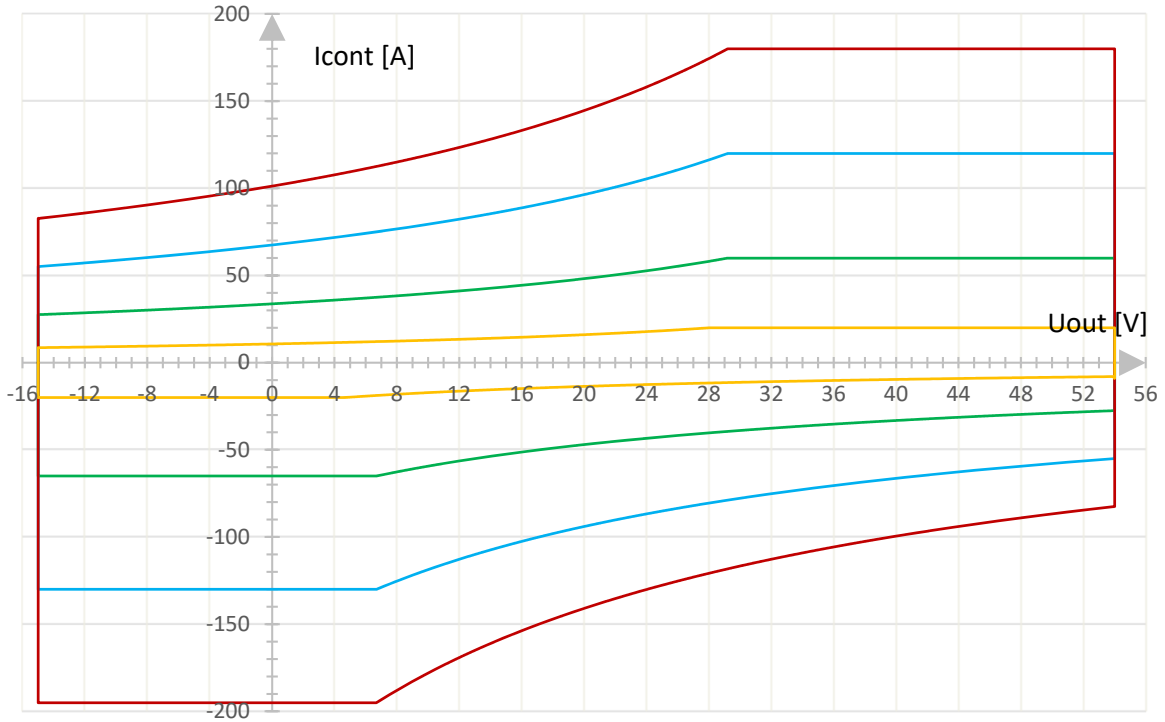

54V Range short-time current I_{short} : LVA1000 - LVA2500 – LVA5000 – LVA7500

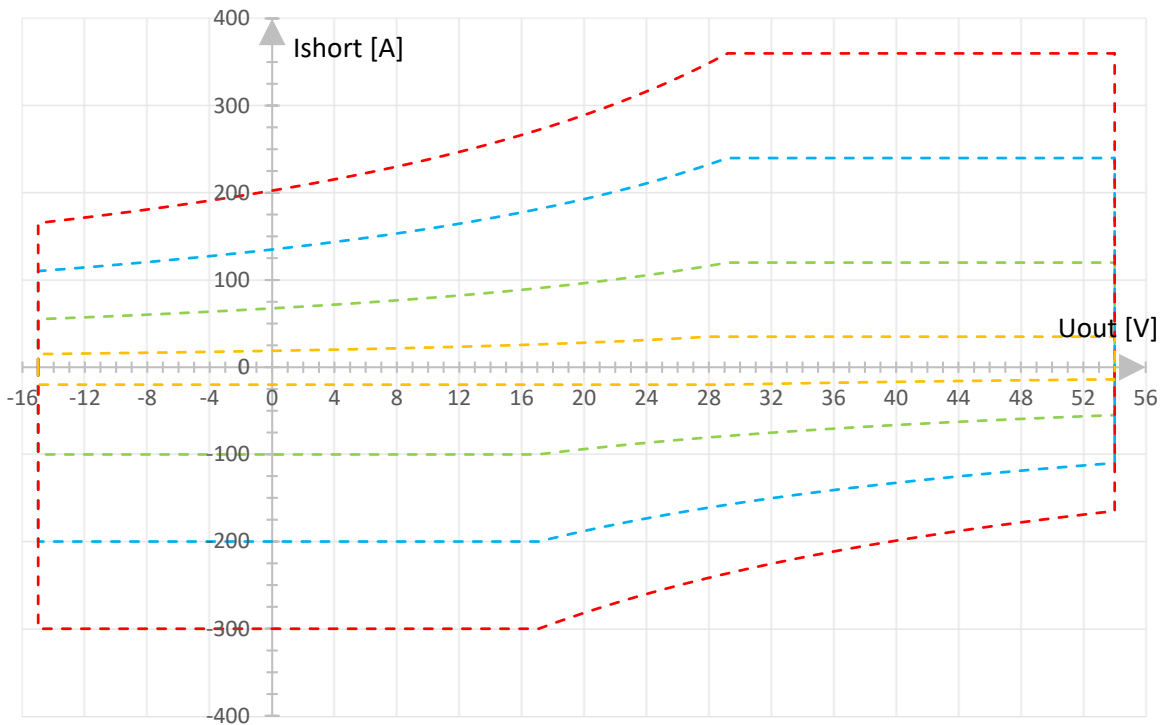

SYMMETRIC AMPLIFIER CHARACTERISTIC – OUTPUT CURRENT CAPABILITY
54V Range continuous current I_{cont} : LVA2500 – LVA5000 – LVA7500

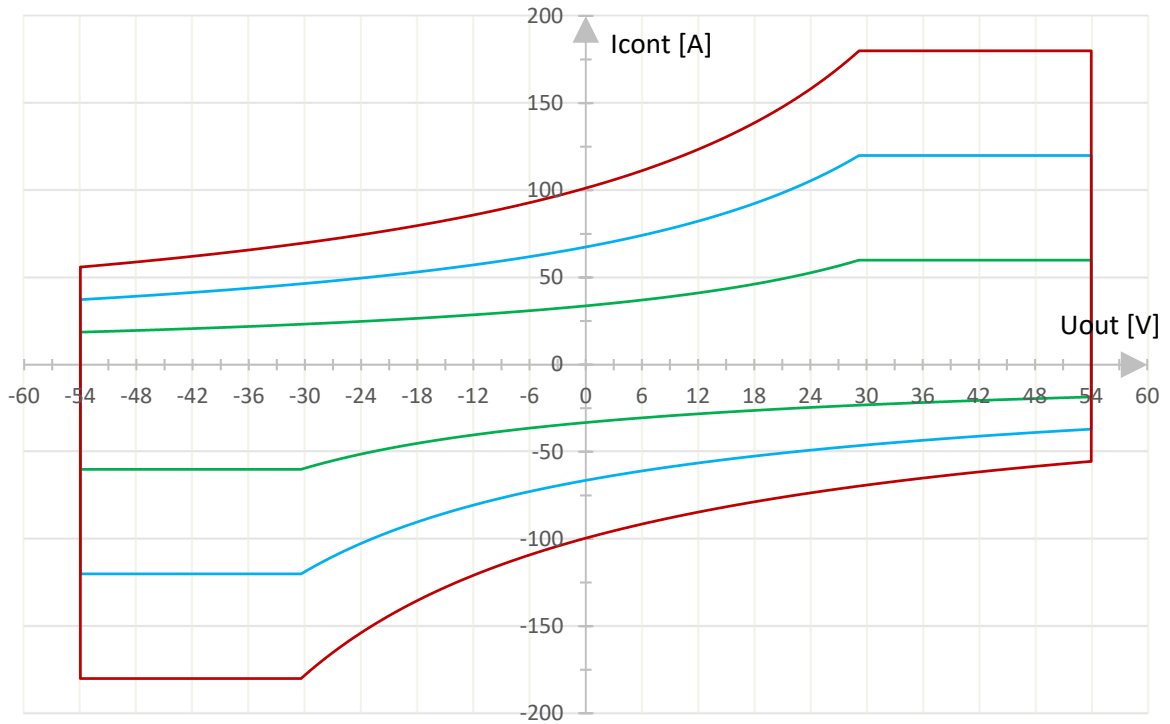

54V Range short-time current I_{short} : LVA2500 – LVA5000 – LVA7500

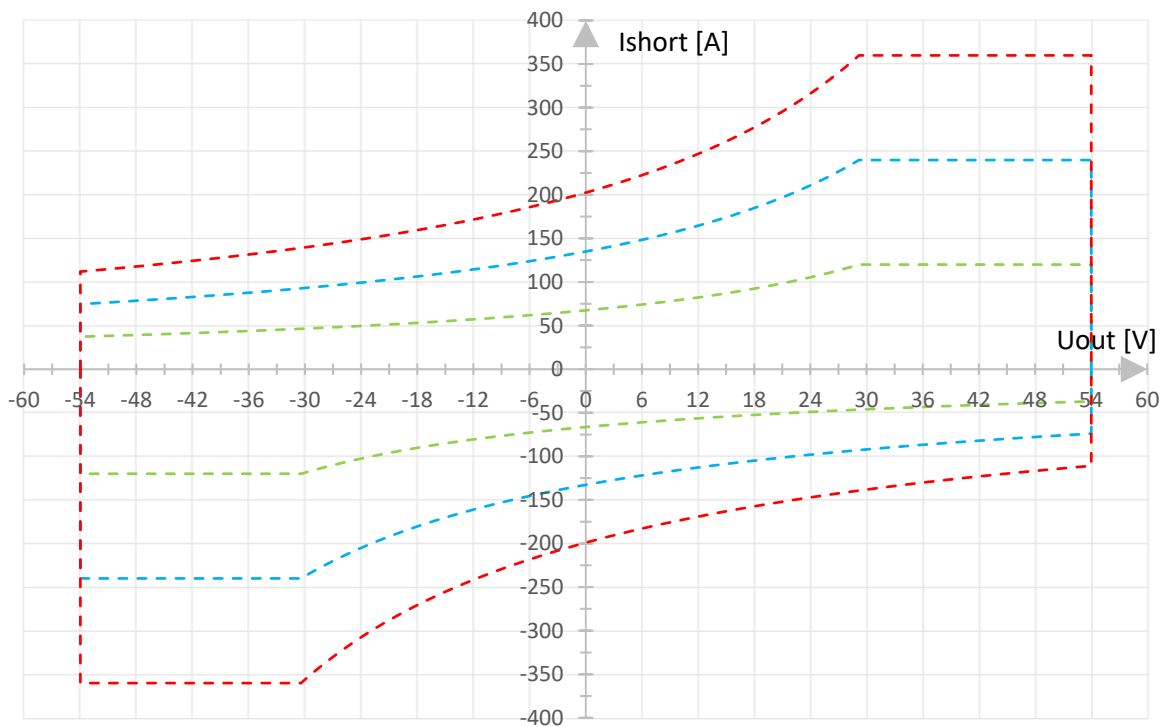

UNSYMMETRIC AMPLIFIER CHARACTERISTIC – OUTPUT CURRENT CAPABILITY
70V Range continuous current I_{cont} : LVA1000 - LVA2500 - LVA5000 - LVA7500

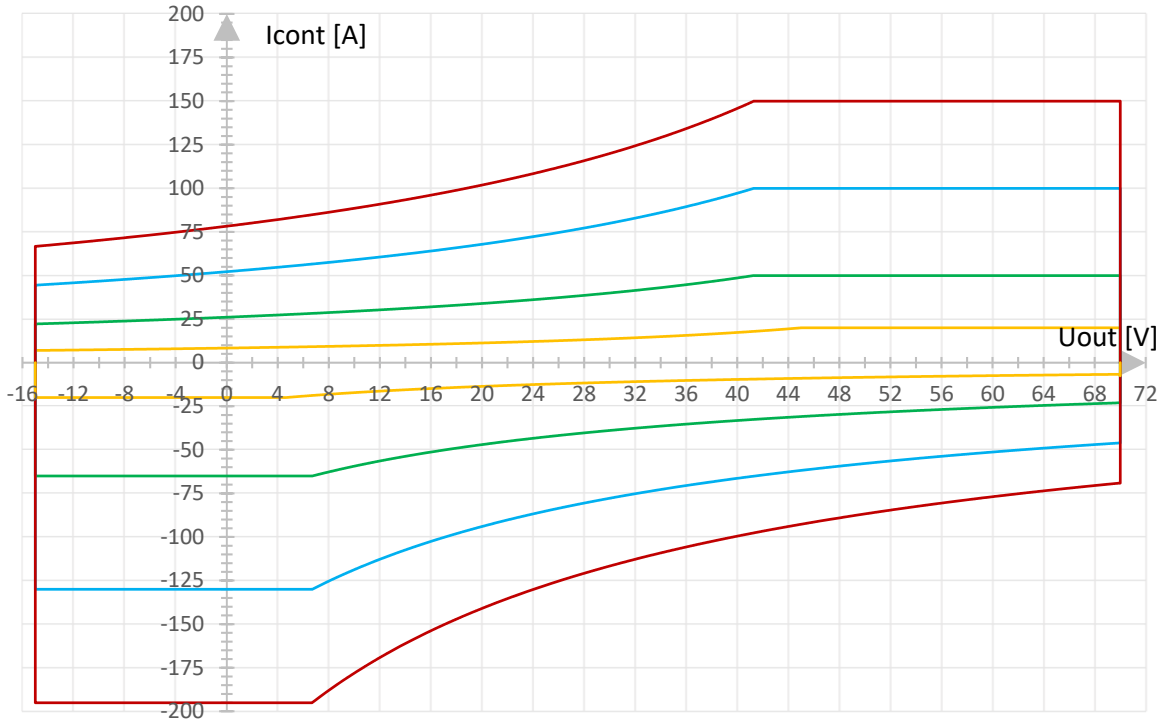

70V Range short-time current I_{short} : LVA1000 - LVA2500 - LVA5000 - LVA7500

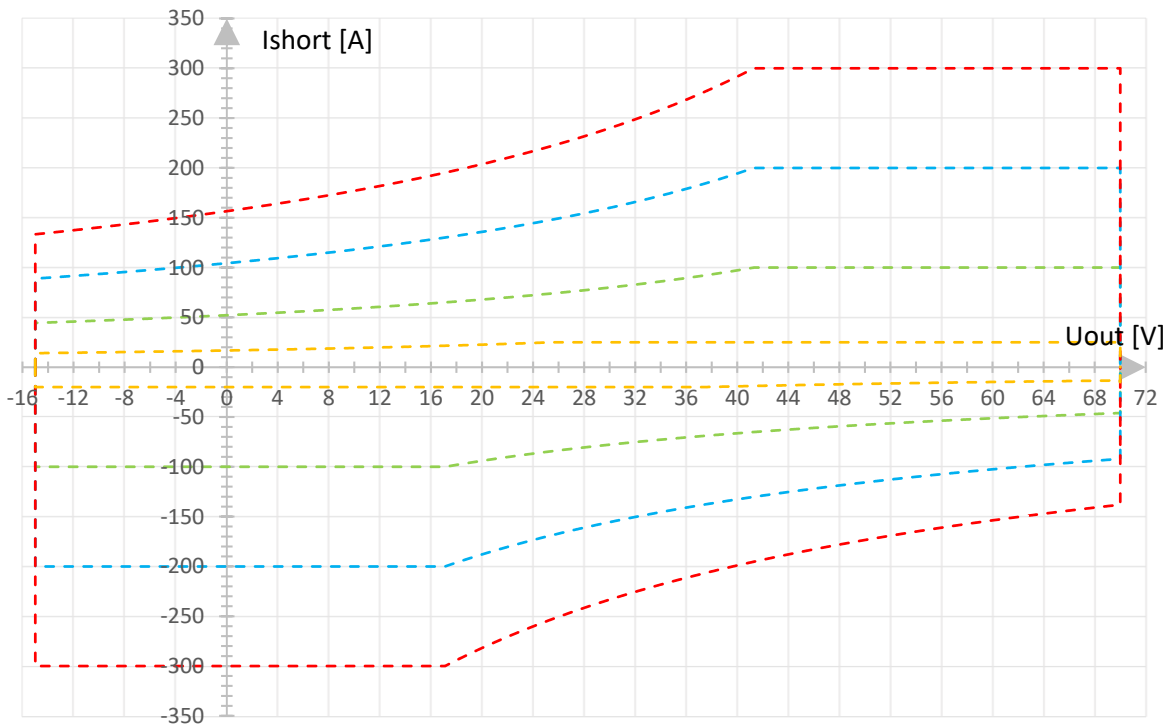

SYMMETRIC AMPLIFIER CHARACTERISTIC – OUTPUT CURRENT CAPABILITY
70V Range continuous current I_{cont} : LVA2500 – LVA5000 – LVA7500

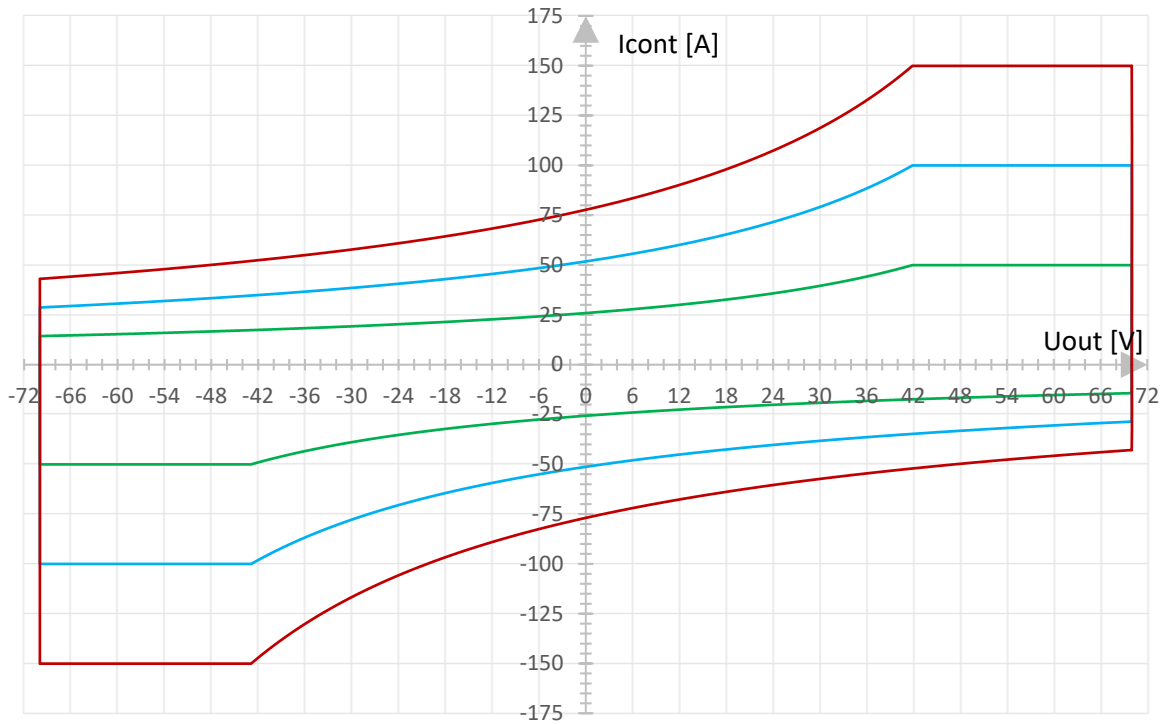

70V Range short-time current I_{short} : LVA2500 – LVA5000 – LVA7500

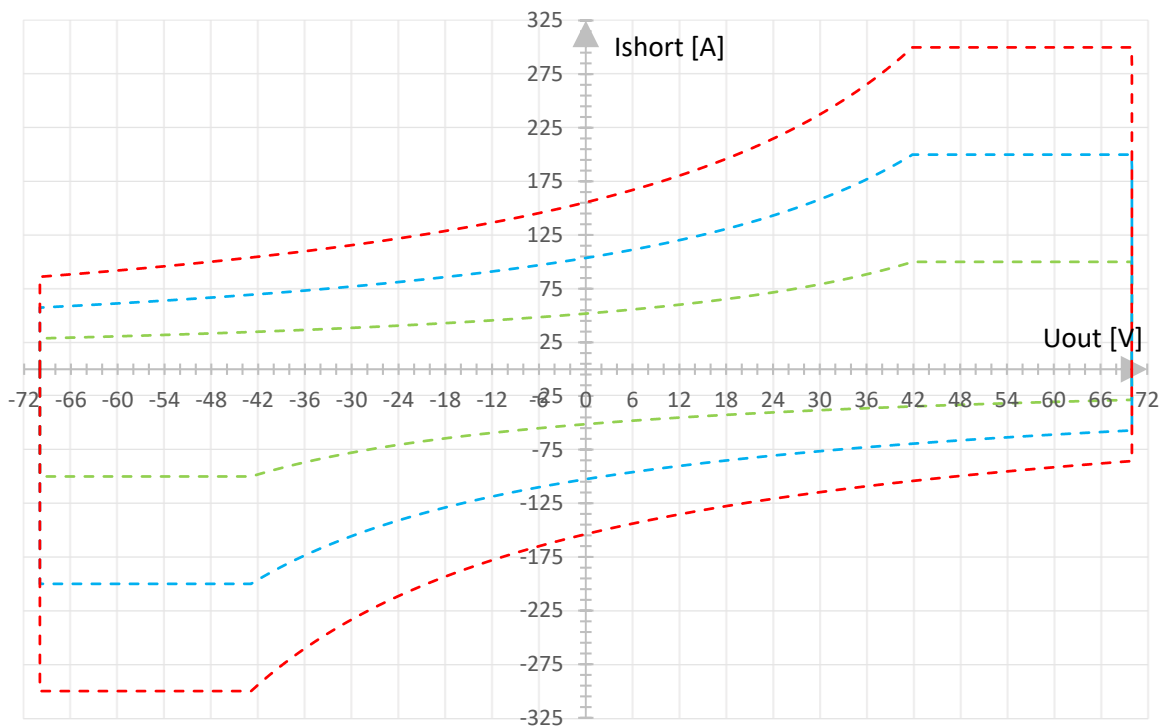

TECHNICAL DATA – TYPE SPECIFIC – UNSYMMETRIC AMPLIFIER

	LVA 1000	LVA 2500	
<i>Max. peak current capability:</i> (at 12/24/48/48 V)	100A	300A	
<i>Continuous sink current capability:</i>	See characteristics diagram	See characteristics diagram	
<i>Continuous power:</i>			
<i>Short-time power:</i> (max 20-30s, duty cycle 1:9)			
<i>Peak power:</i> (max 200ms)			
Nominal Voltages:	<i>Output current capability at maximum output voltage:</i>		
$U_1:$ 0V _{DC} ... 20V _{DC}	See characteristics diagram	See characteristics diagram	
$U_2:$ 0V _{DC} ... 36V _{DC}			
$U_3:$ 0V _{DC} ... 54V _{DC}			
$U_4:$ 0V _{DC} ... 70V _{DC}			
$U_1 \dots U_4:$ -15V _{DC} ... 0V _{DC}			
Digital instrument:	<i>Voltage range:</i>	Autoranging (20/40/80V Ranges)	
	<i>Current range:</i>	12.5A / 25A / 50A / 100A	37.5A / 75A / 150A / 300A
	<i>Accuracy⁽¹⁾:</i>	Voltage (DC): 0.1%	Current (DC): 0.5%
Supply:	<i>Power Supply:</i>	230V (±10%, 50Hz ... 60Hz)	230V/400V (±10%, 50Hz ... 60Hz)
	<i>Protection:</i>	10A	16A
	<i>Connector type:</i>	Schuko	CEE
Housing:	19"-plug-in unit, colour light grey (RAL 7035)		
<i>Dimensions (mm):</i>	Amplifier incl. Power supply (5U) 222x483x700	Amplifier (5U): 222x483x700, Power supply (6U): 267x483x700	
<i>Weight:</i>	approx. 60kg	LVA: approx. 30kg, NT: approx. 90kg	
General:			
<i>Voltage adjustment:</i>	depending on oscillator used		
<i>Load regulation: 0 ... nominal load</i>	max. 0.2%, typ. <0.1%		
<i>Frequency range:</i>	DC ... 300kHz small signal bandwidth		
<i>Noise at output</i>	<5mV _{rms} (<100kHz), <10mV _{rms} (100kHz - 20MHz)		
<i>Slew rate (at load=10Ω):</i>	U: >10V/μs	U: >20V/μs	
Protection circuits:	Overload / Short circuit / Overtemperature		
Input:			
<i>Input voltage: (for max. output)</i>	±5V _p		
Interface:	Ethernet		
Ambient temperature:	10°C up to +40°C		

Remarks

1) of range value

TECHNICAL DATA – TYPE SPECIFIC – UNSYMMETRIC AMPLIFIER

		LVA 5000	LVA 7500
<i>Max. peak current capability:</i> <i>(at 12/24/48/48 V)</i>		600A	900A
<i>Continuous sink current capability:</i>		See characteristics diagram	See characteristics diagram
<i>Continuous power:</i>			
<i>Short-time power:</i> <i>(max 20-30s, duty cycle 1:9)</i>			
<i>Peak power: (max 200ms)</i>			
Nominal Voltages:		<i>Output current capability at maximum output voltage:</i>	
<i>U₁: 0V_{DC} ... 20V_{DC}</i>		See characteristics diagram	See characteristics diagram
<i>U₂: 0V_{DC} ... 36V_{DC}</i>			
<i>U₃: 0V_{DC} ... 54V_{DC}</i>			
<i>U₄: 0V_{DC} ... 70V_{DC}</i>			
<i>U₁ ... U₄: -15V_{DC} ... 0V_{DC}</i>			
Digital instrument:	<i>Voltage range:</i>	Autoranging (20/40/80V Ranges)	
	<i>Current range:</i>	75A / 150A / 300A / 600A	125A / 250A / 500A / 1000A
<i>Accuracy⁽¹⁾:</i>		Voltage (DC): 0.1%	Current (DC): 1%
Supply:	<i>Power Supply:</i>	230V/400V (±10%, 50Hz ... 60Hz)	
	<i>Protection:</i>	32A	32A
<i>Connector type:</i>		CEE	
Housing:		19"-plug-in unit, colour light grey (RAL 7035)	
<i>Dimensions (mm):</i>		Amplifier (8U): 356x483x700 Power supply(12U): 533x483x700	Amplifier (11U): 489x483x700 Power supply(12U): 533x483x700
<i>Weight:</i>		LVA: approx. 65kg, NT: approx. 200kg	LVA: approx. 75kg, NT: approx. 250kg
General:			
<i>Voltage adjustment:</i>		depending on oscillator used	
<i>Load regulation: 0 ... nominal load</i>		max. 0.2%, typ. <0.1%	
<i>Frequency range:</i>		DC ... 300kHz small signal bandwidth	
<i>Noise at output</i>		<5mV _{rms} (<100kHz), <10mV _{rms} (100kHz - 20MHz)	
<i>Slew rate (at load=10Ω):</i>		U: >20V/μs	
Protection circuits:		Overload / Short circuit / Overtemperature	
Input:			
<i>Input voltage: (for max. output)</i>		±5V _p	
Interface:		Ethernet	
Ambient temperature:		10°C up to +40°C	

Remarks

(1) of range value

INCLUDED FUNCTIONS FOR LVA SERIES

	Adjustable current limitation
	Internal resistance compensation
	Floating output Max. voltage between earth and ground of the output of the amplifier: 300V _{rms}
	External floating input V: 0 ... ±5V _{DC}
	Three additional synthesizer
	Event trigger

ADDITIONAL OPTIONS FOR LVA SERIES

OPT.01	IEEE 488 Interface
OPT.02	RS 232 Interface (instead of IEEE 488 Interface)
OPT.05	Output voltage and current monitor (electrically isolated) Probe ratio free adjustable
NT.11.70S.	Symmetrical voltage range V:0 ... 50V _{rms} (±70V _{DC})
OPT.24.	Programmable internal resistance R:0mΩ ... 200.0mΩ/ Accuracy: ±1% of range
OPT.25.	Constant current mode

ADD-ON DEVICE FOR LVA SERIES

OPD.	Overvoltage protection device
------	-------------------------------



LVA 5000 Front panel

Pulse Generator Burst / Surge type HILO CAR-TEST-SYSTEM 14

Optional CAR-Transient Emission TE14
for testing according to ISO 7637

The relating standards:

ISO 7637
ISO 16750
ISO 21848
FMC1278
JLR-EMC-CSv1.04A

Test pulse waveforms

#1

1-5/2000 μ s, 600V ISO

1-5/1000 μ s, 600V ISO/SAE

#2a

1/50 μ s, 600V ISO

Ri = 2/4/10/20/30/

50/90/150 Ω

#3

5/100ns, 800V ISO

Ri = 50 Ω

Vehicle voltages:

12 / 24 / 48 V



The modular system concept allows realisation of different test requirements:

- power supply voltages of 12V, 24V, 42V and 48V
- different power supply currents, nominal power supply current of 50A, 100A and 200A

A microprocessor-controlled 5" touch screen display permits an easy operation of the generator.

The software program CAR-remote permits the PC control of the generator via Ethernet and fiber optic and allows the standardized documentation according to IEC 17025 and the evaluation of test results.

The CAR-TEST-SYSTEM 14 is designed for testing the immunity of the electrical installation of vehicles and components against supply line transients. It allows generation of transient immunity test pulses, pulse #1, #2a and #3 of the ISO 7637-2.

The basic configuration contains the above pulses, a triggerable load switch and an Ethernet interface board. A fast pulse voltage divider to measure the pulse in the electrical system is also integrated.

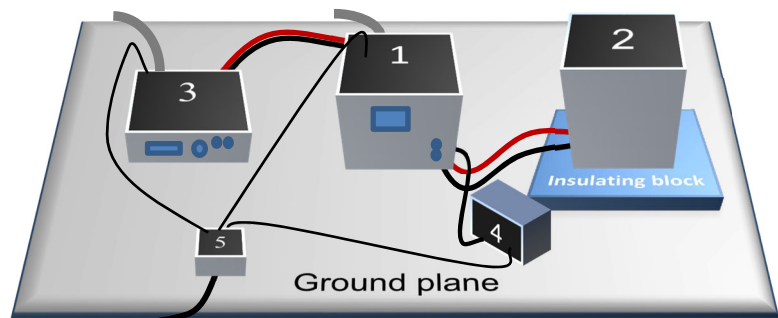

TECHNICAL DATA CAR-TEST-SYSTEM 14

Control:	
<i>Microprocessor controlled touch-panel</i>	7", capacitive
<i>Optical Ethernet interface for remote control of the generator</i>	optional
<i>Interface for saving reports</i>	USB
<i>External trigger input/output</i>	10V at 1kΩ□
<i>Connector for external safety interlock loop</i>	24V _{DC}
<i>Connector for external red and green warning lamps according to VDE 0104</i>	230V, 60W
<i>Mains power</i>	230V, 50Hz/60Hz
Housing:	
<i>Dimensions (mm) W * H * D:</i>	Rack mount 7U 450x310x500
<i>Weight (kg):</i>	35
Surge pulse acc. to #1, #2a ISO 7637-2:2011	
<i>Charging voltage</i>	± (0V ... 600V) ± 10% adjustable
<i>Max. stored energy</i>	18J
<i>Max. charging time</i>	0.5sec ... 5.0sec
<i>Switchable Polarity</i>	positive, negative
<i>Switchable Source resistance</i>	2Ω, 4Ω, 10Ω, 20Ω, 50Ω or 90Ω,
<i>Only with negative pulse polarity:</i>	
<i>Power supply disconnection time, t₂</i>	3 ... 200ms ± 20%
<i>Trigger delay, t₃</i>	< 100μs
ISO 7637-2: 5.6.1 Test Pulse 1 (1b SAE)	
<i>Waveform 1-5/2000μs or 1-5/1000μs</i>	
<i>Impulse voltage U_s</i>	0 ... -600V +/-10%
<i>Rise time, t_r</i>	1.0μs + 0/-0.5μs; 3.0μs +0/-1.5μs
<i>Pulse duration, t_d</i>	2000 μs / 1000 μs ± 20%
ISO 7637-2: 5.6.2 Test Pulse 2a	
<i>Waveform 1-5/2000μs or 1-5/1000μs</i>	
<i>Impulse voltage U_s</i>	0 ... +600V +/-10%
<i>Rise time, t_r</i>	1.0μs +0μs/-0.5μs
<i>Pulse duration, t_d</i>	50μs ± 20%
Burst pulse #3a / #3b acc. to ISO 7637-2:2011:	
<i>Amplitude of burst output voltage</i>	± (25V ... 800V) ± 10% adjustable
<i>Waveform</i>	
<i>Rise time, t_r</i>	5.0ns ± 30%
<i>Pulse duration, t_d</i>	100ns + 100ns/-0ns
<i>Source resistance</i>	R _s =50Ω
<i>switchable Polarity</i>	pos./neg.
<i>Pulse period t₁</i>	1.0μs ... 1.0ms adjustable
<i>Burst duration t₄</i>	0.1ms ... 25ms adjustable
<i>Burst period t₅</i>	10ms ... 1000ms adjustable
<i>Max. continuous burst frequency</i>	20kHz

Power supply switch	
<i>Output current, depending on system type</i>	50A, 100A, 200A
<i>Max. reverse voltage</i>	800V
<i>Transient over voltage protection</i>	>1000V
<i>High short circuit current capability</i>	900A
<i>Protection with automatic circuit breaker</i>	50A, 100A, 200A
<i>Amplifier sense line decoupled from output</i>	built-in
<i>Trigger input, connectable to external modules</i>	built-in
Measurement equipment	
<i>Impulse voltage divider, 4.95 kΩ / 50 Ω</i>	100:1, 1kV _{peak}
PC interface Ethernet 3G	
	built-in

Option CAR-Transient Emission TE14 slow and fast pulse

Triggerable load switch
50/100/200 A, 800 V

Shunt resistors integrated,
switchable 10 Ω / 20 Ω / 40 Ω
The TE14 is used to check the transient transition behaviour while switching loads on the vehicle electrical system. It consists of two trigger able circuit breakers (electronically or mechanically), an artificial network, a control unit for operating the device, and optionally an external power supply.



The TE14 can perform the "Transient Emission Test" for "slow pulses" and "fast pulses" according to ISO 7637-2. It features a microprocessor controlled user interface and a display unit. The operator can define his own test sequences.

The test-parameters are set and displayed via a 5" touch screen display and can be recorded during the test on an USB stick. The device can be operated individually or in conjunction with the CAR-TEST-SYSTEM 14 and can be controlled by PC software.

TECHNICAL DATA CAR-TRANSIENT-EMISSION TE14

Control:	
<i>Microprocessor controlled touch panel</i>	5", 800X480, 24bit
<i>Optical Ethernet Interface for remote control of the generator</i>	Optional
<i>Interface for saving reports</i>	USB
<i>External trigger input /output</i>	10V at 1k Ω
<i>Connector for external safety interlock loop</i>	24V _{DC}
<i>External red and green warning lamps acc. to VDE 0104</i>	230V, 60W
<i>Mains power</i>	230V, 50/60Hz
Housing:	
<i>Dimensions (mm) W * H * D:</i>	desk top case 450x320x180
<i>Weight (kg):</i>	35
Transient Emission Test, Power Switch Transients:	
acc. to ISO 7637-2	
<i>Max. operating voltage</i>	70V
<i>High short circuit current capability</i>	900A
<i>Voltage drop over switch at 25A</i>	< 0,2V
<i>Switching time</i>	< 300ns
<i>Transient over voltage protection</i>	> 500V
<i>Nominal voltage</i>	0 ... 100%
<i>Turn off time</i>	1 ... 1000s
<i>Turn on time</i>	5 ... 1000ms
<i>Number of tests</i>	1 ... 1000
Artificial network:	
<i>Series inductance</i>	5 μ H, 100A
<i>Load impedance</i>	0.1 μ F + 50 Ω
<i>Load resistor R_s, switchable</i>	10/20/40 Ω
<i>Connectors for external load resistor, 2.0 Ω</i>	built-in
<i>Artificial network</i>	on/off
Power supply switch	
<i>Max. output current</i>	50/100/200A
<i>Max. reverse voltage</i>	800V
<i>Trigger input, connectable to external modules</i>	built-in
Measurement probes, Transient immunity test	
<i>Impulse voltage divider</i>	100:1, 10MHz, 1kV _{peak}

µs-Switch type EMS 100

Simulation of micro cut-offs and discharge of load currents in automotive supply networks

The relating standards:
 LV 124
 VDA 320 (LV 148)
 Renault 36-00-808L 6.1.10
 PSA B21 7110 7.1.13

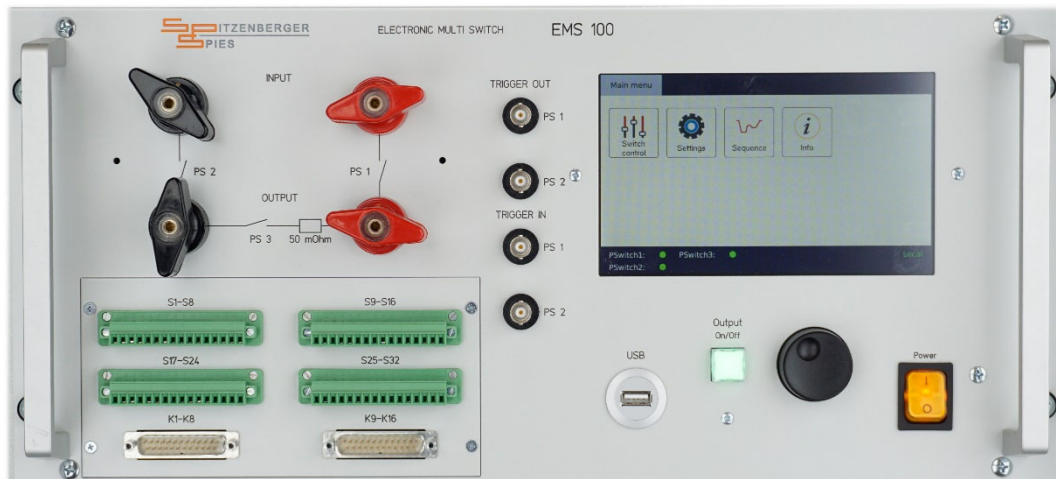

The µs-Switch type **EMS** is a very fast electronic switch combination for testing accordingly to several automotive test standards. Originally designed for the LV124 standard, the flexibility of EMS extends its use to the VDA 320 (LV148) and various manufacturer specific standards.

The ability of generating very short voltage drops with 10µs duration requires a very fast rise- and fall-time of the electronic switches. The LV124 standard specifies the rise- and fall-time t_r / t_f as 10% of the desired testing cycle t_1 (Fig. 2).

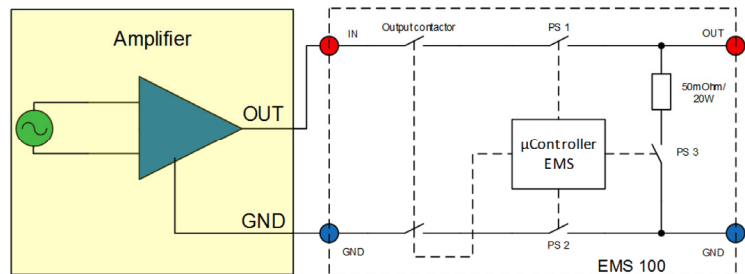

Fig. 1: Schematic diagram

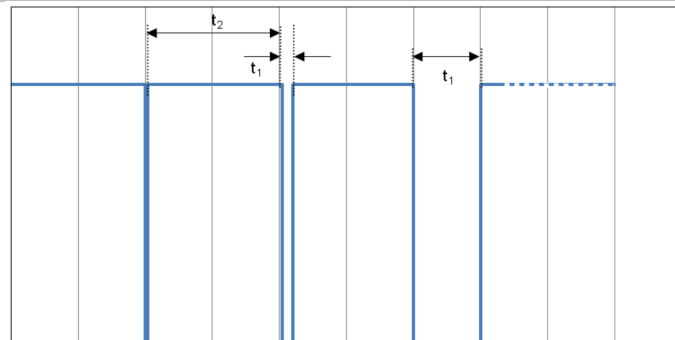

Fig. 2: Test pulses accordingly to LV124/VDA 320 (LV148)

With the EMS it is also possible to switch supply and ground lines independently.

The front-panel touch screen supplies an easy to use interface.

The EMS has three upgrade slots for options like SSW or Relay. These options can be selected according to the application needs.

SSW and Relays are used for testing according to LV124, PSA and other relating standards.

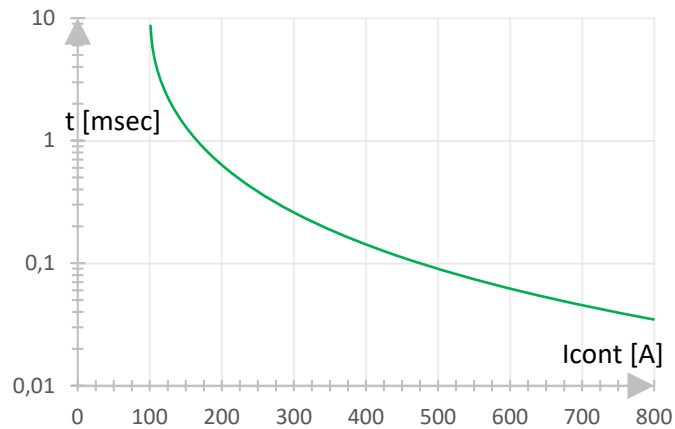

Fig. 3 Max. Current Characteristic

TECHNICAL DATA EMS 100

		EMS 100
Input voltage:		0 ... 70V _{DC}
Output:		
<i>Output current capability:</i>		100A _{DC} continuous
<i>Short time current capability:</i>		See fig. 2
<i>Internal Impedance:</i>		approx. 10mΩ at nominal current
<i>Rise time t_r / Fall time t_f @1kΩ:</i>		<1μs / <10μs
<i>Rise time t_r / Fall time t_f @100Ω:</i>		<1μs / <1μs
<i>Rise time t_r / Fall time t_f @10Ω:</i>		<1μs / <1μs
<i>Rise time t_r / Fall time t_f @1Ω:</i>		<1μs / <1μs
<i>Min. adjustable pulse width:</i>		1μs
Protection circuits:		overload / short circuit / overtemperature, overvoltage limitation for inductive loads
Interface:		Ethernet
Trigger PS1+PS2:	<i>Output</i>	TTL level (+5V)
	<i>Input:</i>	5 ... 24V _{DC}
Power Supply:		230V (±10%, 50Hz / 60Hz) Safety plug
<i>Protection:</i>		2A fuse
Ambient temperature:		10 ... 40°C
Housing:		19"-plug-in unit; 5U
<i>Dimensions (mm):</i>		485x455x223
<i>Weight:</i>		15.5kg
<i>Cooling:</i>		Temperature-controlled fans
<i>Extension slots for SSW/Relay:</i>		3

TECHNICAL DATA OPTIONS:

Option EMS.CAL:	Calibration Kit LV124
<i>Resistor types:</i>	high precision non-inductive measurement resistors
	power capability / accuracy
<i>1kΩ:</i>	5 Watt / 1%
<i>100Ω:</i>	5 Watt / 1%
<i>1Ω:</i>	125 Watt / 1%
<i>Monitoring output:</i>	BNC Connector
<i>Dimensions (mm):</i>	114x64x55
Option EMS.SSW.1.16:	SSW module 1A/16
<i>Number of switches:</i>	16 per module
<i>Input voltage:</i>	0 ... 70V _{DC}
<i>Output current capability:</i>	1A _{DC}
<i>Rise time t_r / Fall time t_f @ 1kΩ:</i>	<1μs / <1μs
<i>Rise time t_r / Fall time t_f @ 100Ω:</i>	<1μs / <1μs
<i>Protection:</i>	2A fuse
Option EMS.SSW.4.8:	SSW module 4A/8
<i>Number of switches:</i>	8 per module
<i>Input voltage:</i>	0 ... 70V _{DC}
<i>Output current capability:</i>	4A _{DC}
<i>Rise time t_r / Fall time t_f @ 1kΩ:</i>	<1μs / <1μs
<i>Rise time t_r / Fall time t_f @ 100Ω:</i>	<1μs / <1μs
Option: EMS.K.2.16:	Relay module 2A/16
<i>Number of relays:</i>	16 per module –contact type 2C
<i>Max. switching current (real load):</i>	2A _{DC}
<i>Max. switching voltage (real load):</i>	70V _{DC}
<i>Max. switching power (real load):</i>	60W
Option: EMS.IEEE:	IEEE488 Interface / RS232 Interface

Load dump pulse generator type LDS

The relating standards:
 ISO 16750-2, test pulse A and B
 Ford FMC 1278
 JLR-EMC-CSv1.04A
 SAE J 1113-11
 PSA B21 7110
 Renault 36-00-801

The Load Dump Generator LDS generates the pulses A and B according to ISO16750-2 and many other automotive standards.

These pulses may occur in the event of a discharged battery being disconnected while the alternator is generating charging current and with other loads remaining on the alternator circuit at this moment. With the touch-screen panel the pulses can be selected and started easily.

For automated tests a user-friendly software application is available.



ISO Test pulses A, B Load Dump

Pulse 5a represents the transient produced due to sudden disconnection of the battery from the alternator. Pulse 5b represents a voltage clamped transient produced due to sudden disconnection of the battery from an alternator fitted with Central Load Dump Protection.

ISO pulse A:

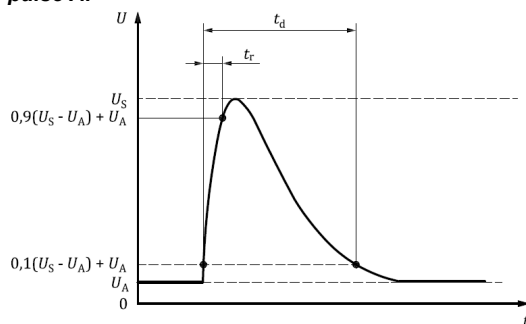

Test without centralized load dump suppression
 Images taken from the ISO 16750

ISO pulse B:

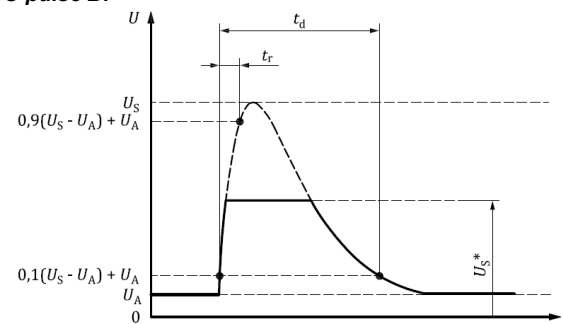

Test with centralized load dump suppression

ISO 16750-2: 4.6.4.2.2 LOAD DUMP TEST WITHOUT CENTRALIZED SUPPRESSION

Software parameters of the LDS application software

Test options:

Parameter	Value	Unit
UA	14	V
US	101	V
Uend	14	V
t0 (one time)	1	s
tr	10	ms
td	400	ms
Ri	2	Ω
Pulses intervals	1	min
Number of cycles	10	
Use an alternative voltage source	<input type="checkbox"/>	

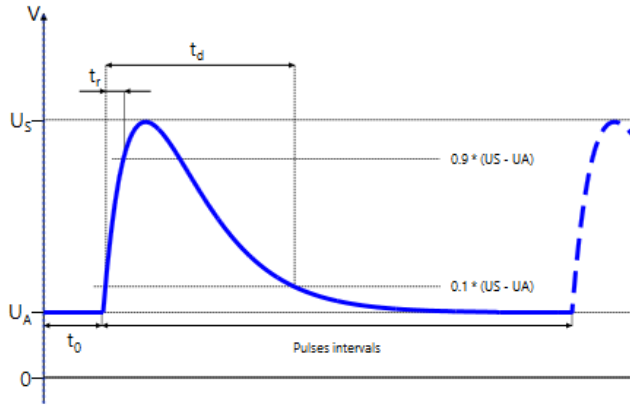

Measurement of the ISO pulse with the above parameters

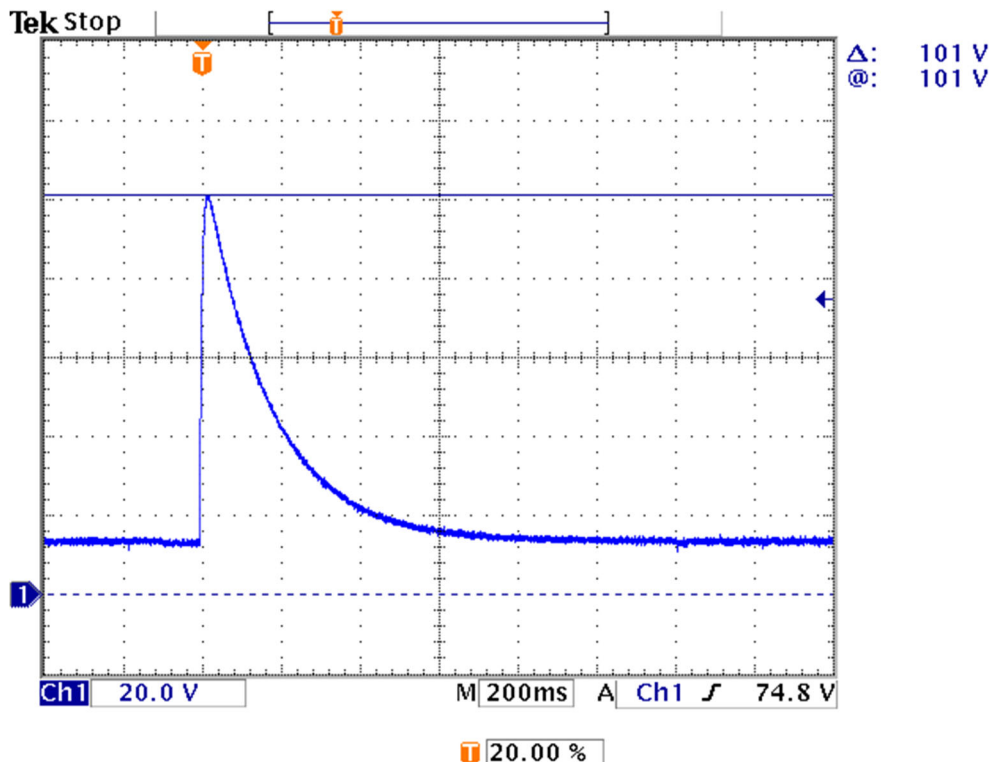

ISO 16750-2: 4.6.4.2.3 LOAD DUMP TEST WITH CENTRALIZED SUPPRESSION

Software parameters of the LDS application software

Test options:

Parameter	Value	Unit
UA	14	V
US	101	V
US*	35	V
Uend	14	V
t0 (one time)	1	s
tr	10	ms
td	400	ms
Ri	4	Ω
Pulses intervals	1	min
Number of cycles	5	
Use an alternative voltage source	<input type="checkbox"/>	

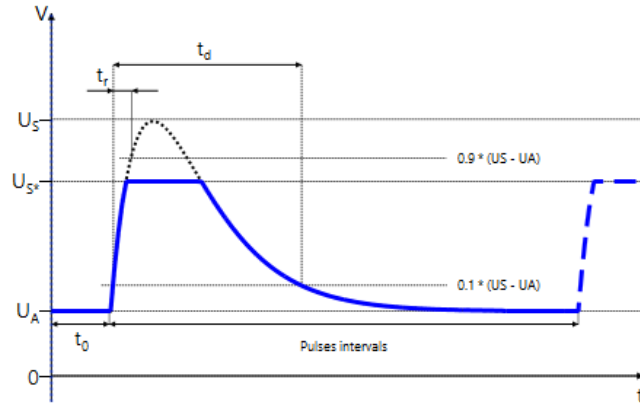

Measurement of the ISO pulse with the above parameters

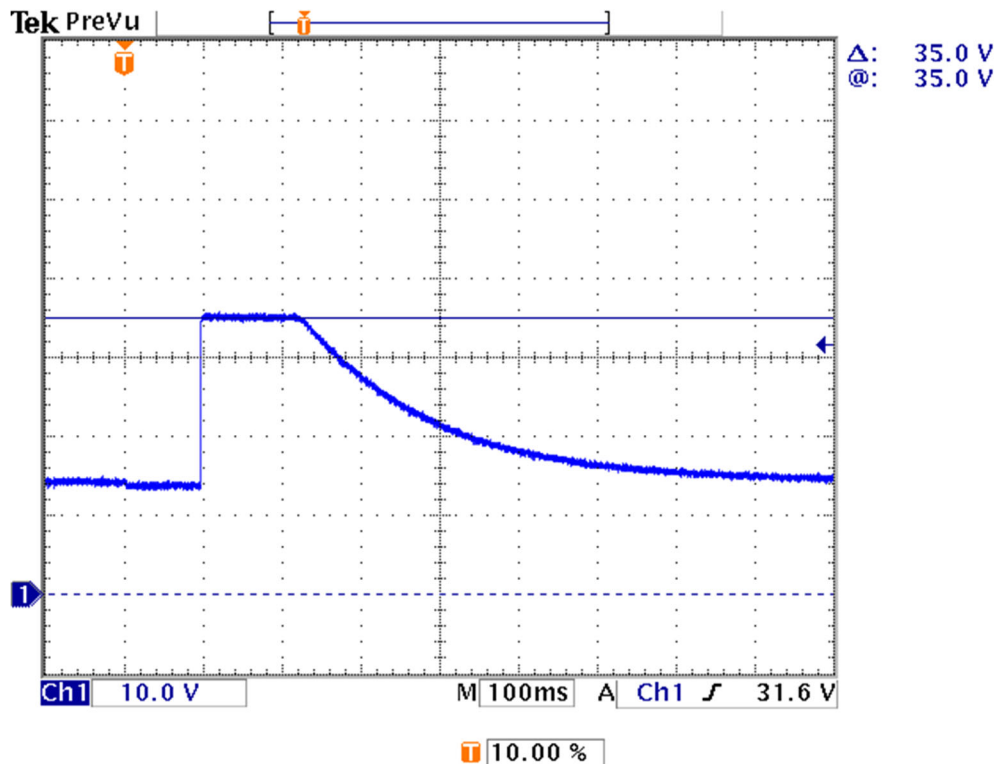

TECHNICAL DATA

Type	LDS 100	LDS 200
Idle output voltage:	U _{0,max} : 250V	
Pulses:		
Pulse width:	t _{dmax} : 0.4F*R _i	
Max. energy:	W _{max} : U ₀ ² *22mF	
Repetition rate:	min. 10s	
Source resistor:	0.4Ω ... 12.5Ω	
Integrated suppressor network	integrated adjustable diode suppression network	
Battery supply:		
Max. voltage:	70V	70V
Cont. current :	100A	200A
Interface:	Ethernet 100M	
Power supply:		
Supply voltage:	230V (±10%, 50Hz ... 60Hz)	
Contactor type:	safety-plug	
Ambient temperature:	0°C ... +40°C	
Housing:	19"-plug-in unit (7U), colour light grey (RAL 7035)	
Dimensions (mm):	approx. 267x483x700	
Weight:	approx. 60kg	

Main menu	Control	
Profile	ISO 16750-2 (12V-System)	R _i <input type="text" value="2"/> Ω Delete
U _A	<input type="text" value="0"/> V	U _S * <input type="text" value="110"/> V
Open circuit conditions	Loaded conditions	Save
U _S <input type="text" value="100"/> V	U _S <input type="text" value="50"/> V	
t _d <input type="text" value="400"/> ms	t _d <input type="text" value="200"/> ms	
t _r <input type="text" value="7.5"/> ms	t _r <input type="text" value="4"/> ms	Start
U: 0.036 V	Charged: ●	Range: +225 V
I: 0.043 A	Pulse Active: ●	I-Limit: ● Remote
		Overload: ●

LDS touchpanel screenshot

SPS Automotive software modules

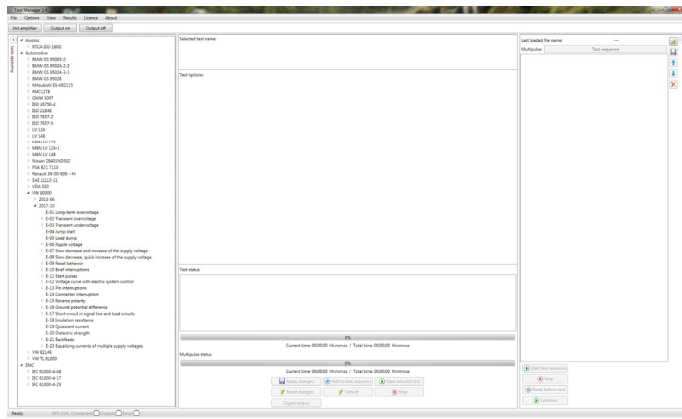

Supported Windows Versions:

Windows 7

Windows 10

Software modules for automotive standards testing and their requirements of specific hardware

Software module ISO 7637 SAE (S.AU.ISO.7637)

Testing according to ISO 7637-2 (2011-03)

4.3 Voltage transient emission test

4.3.2 Test set-up for slow pulses

4.3.3 Test set-up for fast pulses

(HARDWARE REQUIREMENT: CAR-SWITCH-TE 14)

5.6 Test pulse generator for immunity testing

5.6.1 Test pulse 1

5.6.2 Test pulses 2a and 2b

5.6.3 Test pulses 3a and 3b

(HARDWARE REQUIREMENT: CAR-TEST-SYSTEM 14)

Testing according to ISO 7637-3 (2016-07)

4.3 Test pulse generator

4.3.2 Fast transient test pulses a and b

4.3.3 Slow transient test pulses

(HARDWARE REQUIREMENT: CAR-TEST-SYSTEM 14)

Testing according to SAE J 1113-11 (2012-01/2017-06)

8. Test pulses

Fig. 2 Test pulse 1, supply disconnection from inductive loads

Fig. 3 Test pulse 2a sudden interruption of current

Fig. 4 Test pulse 2b transient from dc motors

Fig. 5 Test pulse 3a switching spikes

Fig. 6 Test pulse 3b switching spikes

Fig. 7 Test pulse 4 single pulse

(HARDWARE REQUIREMENT: CAR-TEST-SYSTEM 14)

Fig. 8 Test pulse 5a, 5c load dump single pulse unsuppressed

Fig. 9 Test pulse 5b load dump single pulse centralized suppression

(HARDWARE REQUIREMENT: Load dump generator LDS)

Software module ISO 16750-2 (S.AU.ISO.16750.2)

Testing according to ISO 16750-2 (2012-11)

4.2 Direct current supply voltage

4.3 Overvoltage (test pulse for maximum dynamic voltage)

4.4 Superimposed alternating voltage (50Hz ... 25kHz)

4.5 Slow decrease and increase of supply voltage

4.6 Discontinuities in supply voltage

(HARDWARE REQUIREMENT: Load dump generator LDS)

4.7 Reversed voltage (test at the negative voltage)

4.8 Ground reference and supply offset

(HARDWARE REQUIREMENT: Additional amplifier or an external battery)

4.9 Open circuit tests (interruption of supply voltage)

4.10 Short-circuit protection

Signal circuits (short circuits are applied to the signal circuits)

Load circuits (short circuits are applied to the load circuits)

(HARDWARE REQUIREMENT: Electronic switch EMS 100 including option EMS.K.2.16)

Software module ISO 21848 (S.AU.ISO.21848)

Testing according to ISO 21848 (2005-04)

- 4.1 Direct current (test at the minimum and maximum DC voltage)
- 4.2 Overvoltages (test pulse for maximum dynamic voltage)
- 4.3 Superimposed alternating voltage (50Hz ... 20 kHz)
- 4.4 Slow decrease and increase of supply voltage
- 4.5 Discontinuities in supply voltage
- 4.6 Reversed voltage (test at the negative voltage)
- 4.7 Open-circuit tests (interruption of supply voltage)
- (HARDWARE REQUIREMENT: Electronic switch EMS 100 including option EMS.K.2.16)
- 4.8 Short-circuit protection
 - Signal circuits (short circuits are applied to the signal circuits)
 - Load circuits (short circuits are applied to the load circuits)
- (HARDWARE REQUIREMENT: Electronic switch EMS 100 including option EMS.K.2.16)

Software module LV 124 (S.AU.LV124)

Testing according to LV 124 (2013-06), BMW GS 95024-3-1 (2013-06), BMW GS 95024-2-2 (2011-02) Mercedes-Benz MBN LV 124-1 (2013-06) and VW 80000 (2013-06/2017-10)

- E-01 Long-term overvoltage
- E-02 Transient overvoltage
- E-03 Transient undervoltage
- E-04 Jump start
- E-05 Load dump
- E-06 Component immunity to ripple on power supply leads
- (HARDWARE REQUIREMENT: Option OPT.24: programmable internal resistance of the LVA)
- E-07 Slow decrease and increase of the supply voltage
- E-08 Slow decrease, quick increase of the supply voltage
- E-09 Reset behaviour
- E-10 Short interruptions
- (HARDWARE REQUIREMENT: Electronic switch EMS 100)
- E-11 Start pulses / cranking profile
 - Test 1 - Cold start
 - Test 2 - Warm start
- E-12 Voltage curve with IGR
- E-13 Pin interruption
- (HARDWARE REQUIREMENT: Electronic switch EMS 100 including Option EMS.SSW)
- E-14 Connector interruption
- (NOTE: For this test E-14 the LVA system provides only the voltage source)
- E-15 Reverse polarity
- (HARDWARE REQUIREMENT: Option OPT.24: programmable internal resistance of the LVA)
- E-16 Ground offset
- (HARDWARE REQUIREMENT: Electronic switch EMS 100 including option EMS.K.2.16 and an additional amplifier or an external battery)
- E-17 Short circuit in signal circuit and load circuits
- (HARDWARE REQUIREMENT: Electronic switch EMS 100 including option EMS.K.2.16 or EMS.SSW.4.8 or EMS.SSW.1.16)
- E-19 Closed circuit current
- (HARDWARE REQUIREMENT: External current measurement unit)
- E-21 Backfeeds
- (HARDWARE REQUIREMENT: Electronic switch EMS 100)

Additional / Modified test steps acc. to BMW GS 95024-2-2 (2011-02)

- E-02 Transient overvoltage (18V pulse)
- E-11 Start pulses / cranking profile
- E-19 Quiescent current
- E-40 Very brief voltage drop
- E-41 Brief off / on for bus nodes
- E-42a Voltage impulses due to switch-off of loads
- (HARDWARE REQUIREMENT: Electronic switch EMS 100 including option EMS.K.2.16)

Software module LV 148 / VDA 320 (S.AU.LV148)

Testing according to LV 148 (2013-09), VDA 320 (2015-01)

BMW GS 95026 (2013-10), Mercedes-Benz MBN LV 148 (2013-11) and VW 82148 (2013-09)

E48-01a Long-term overvoltage

E48-01b Overvoltage in backfeeding components

(NOTE: For this test E48-01b the LVA system provides only the voltage source)

E48-02 Transient overvoltage

(HARDWARE REQUIREMENT: Option OPT.24: programmable internal resistance of the LVA)

E48-03 Transient process in the lower range with limited function

E48-04 Recuperation

E48-05 Superimposed AC voltage

(HARDWARE REQUIREMENT: Option OPT.24: programmable internal resistance of the LVA)

E48-06 Slow decrease and increase of the supply voltage

E48-06 for operation with storage, part 1

E48-06 for operation with storage, part 2

E48-07 Slow decrease, quick increase of the supply voltage

E48-08 Reset behaviour

E48-09 Short interruptions

(HARDWARE REQUIREMENT: Electronic switch EMS 100)

E48-10 Start pulses

E48-11 Loss of ground BN48

(HARDWARE REQUIREMENT: Electronic switch EMS 100 including Option EMS.SSW.1.16 and an additional amplifier or an external battery)

E48-12 Ground offset

(HARDWARE REQUIREMENT: Electronic switch EMS 100 including option EMS.K.2.16. and an additional amplifier or an external battery)

E48-13 Internal dielectric strength

E48-14 Closed-circuit current

(HARDWARE REQUIREMENT: External current measurement unit)

E48-15 Operation in the range without functional limitation

E48-16 Operation in the upper range with functional limitation

E48-17 Operation in the lower range with functional limitation

E48-18 Overvoltage range

E48-19 Undervoltage range

E48-20 Fault current, part 1 and part 2

(NOTE: For this test E48-20 the LVA system provides only the voltage source)

E48-21 Short circuit in signal circuit and load circuits

(HARDWARE REQUIREMENT: Electronic switch EMS 100 including option EMS.K.2.16)

Software module BMW GS 95003-2 (S.AU.BMW.95003.2)

Testing according to BMW GS 95003-2 (2010-01)

5.2.1.1 Testing for immunity to 18V transient

5.2.1.2 b) Component immunity to ripple on power supply leads

5.2.1.3.1 Slow decreasing / slow increasing of operating voltage

5.2.1.3.2 Slow decreasing / fast rise

5.2.1.3.3 IGR, development of voltage

5.2.1.4 Ground offset

(HARDWARE REQUIREMENT: Additional amplifier or an external battery)

5.2.1.5 Cranking profile (Figure 14 and Figure 15)

5.2.1.6 Very brief voltage dip

5.2.1.7 Brief voltage dip

5.2.1.7.1 Brief off / on for bus nodes

5.3.1 Quick chargers / jump start

5.3.3 Protection against polarity reversal

Software module FORD-FMC 1278 (S.AU.FMC.1278)

Testing according to Ford FMC 1278

RI 130 Coupled immunity

(**HARDWARE REQUIREMENT:** Transient generator TDG/Ford, CISPR 25 compliant artificial network, coupling test fixture)

RI 150 Coupled immunity

(**HARDWARE REQUIREMENT:** Additional amplifier or external battery, CISPR 25 compliant artificial network, coupling test fixture)

CI 210 Immunity from continuous power line disturbances

CI 220 Immunity from transient disturbances

(**HARDWARE REQUIREMENT:** For pulses A1, A2-1, A2-2, C1 and C-2 Transient generator TDG/Ford.
For pulses E and F1 CAR-TEST-SYSTEM 14.

NOTE: The transient pulses G1 and G2 are not covered with this software version

CI 230 Immunity from power cycling

(**HARDWARE REQUIREMENT:** Three additional amplifiers, e.g. LPA 50)

CI 250 Immunity to ground voltage offset

(**HARDWARE REQUIREMENT:** Voltage adaption UT Ford CI250 and external battery or second amplifier, LVA option NT.11.70S)

CI 260 Immunity to voltage dropout

(**HARDWARE REQUIREMENT:** For waveform F the relay unit in the transient generator TDG/Ford is required.)

CI 270 Immunity to voltage overstress

Software module General Motors GMW 3097 (S.AU.GMW.3097)

Testing according to General Motors GMW 3097 (2012-04)

3.5.1 CE, Transients

(**HARDWARE REQUIREMENT:** CAR TE 14)

3.5.2 CI, Transients on power lines

(**HARDWARE REQUIREMENT:** Pulses 1, 2a, 3a and 3b require the CAR-TEST-SYSTEM 14,
the simulation of load dump transients requires the load dump generator LDS)

3.5.3 CI, Coupling to other than power supply lines (CCC or DCC to I/O)

(**HARDWARE REQUIREMENT:** Capacitive coupling clamp CDN 2012)

3.5.4 CI, Coupling to other than power supply lines (CCC or DCC to sensors only)

(**HARDWARE REQUIREMENT:** Capacitive coupling clamp CDN 2012)

3.5.5 CI, Coupling to other than power supply lines (DCC on I/O and regulated supply lines)

(**HARDWARE REQUIREMENT:** Capacitive coupling clamp CDN 2012)

3.5.6 CI, Coupling to other than power supply lines (alternator direct capacitor coupling)

(**HARDWARE REQUIREMENT:** Capacitive coupling clamp CDN 2012)

Software module Mitsubishi ES-X82115 (S.AU.Mit.82115)

Testing according to Mitsubishi ES-X82115 rev. D (2009-03)

6.1 Supply voltage range

6.2 Ignition off draw (IOD)

6.3 Supply voltage ripple

7.2 Supply voltage drop out

(**HARDWARE REQUIREMENT:** Electronic switch EMS 100)

7.3 Supply voltage dips

7.4 Engine cranking low voltage

7.6 Slow decreases and increase of supply voltage

8.1 Defective regulation (full-fielded alternator)

8.2 Jump start

8.3 Load dump

(**HARDWARE REQUIREMENT:** Load dump generator LDS)

8.4 Reverse supply voltage

9.1 Immunity to short circuits in the supply voltage input and load output lines

(**HARDWARE REQUIREMENT:** Electronic switch EMS 100 including option EMS.K.2.16)

9.2 Immunity to short circuits in I/O signal lines

(**HARDWARE REQUIREMENT:** Electronic switch EMS 100 including option EMS.K.2.16)

9.4 Supply voltage offset

(**HARDWARE REQUIREMENT:** Additional amplifier or an external battery)

9.5 Ground reference offset

(**HARDWARE REQUIREMENT:** Additional amplifier or an external battery)

10.1 Operating and voltage stress

10.2 Stall

Software module PSA / Renault (S.AU.PSA.REN)

Testing according to PSA B21 7110 (2012-07)

7.1 ELECTRICAL RESISTANCE TESTS FOR THE EQUIPMENT CONNECTED TO THE LOW VOLTAGE NETWORK (12V)

- 7.1.1. EQ/TE 01: Resistance to usual power supply voltages
- 7.1.2. EQ/TE 08: Resistance to the variations of supply voltage in the usual "voltage control" range
(HARDWARE REQUIREMENT: Option OPT.24: programmable internal resistance of the LVA)
- 7.1.3. EQ/TE 07: Resistance to exceptional supply voltage
- 7.1.4. EQ/TE 02: Resistance to slow decrease and increase power of supply voltage
- 7.1.5. EQ/TE 03: Re-initialization test
- 7.1.6. EQ/TE 04: Resistance to unusual power supply voltages
- 7.1.7. EQ/TE 05: Resistance to ground and to the positive supply voltages short circuit
(HARDWARE REQUIREMENT: Electronic switch EMS 100 including option EMS.K.2.16)
- 7.1.9. EQ/IC 01: Resistance to pulses 1 and 2a
(HARDWARE REQUIREMENT: CAR-TEST-SYSTEM 14)
- 7.1.10. EQ/IC 10: Resistance to pulses on the outputs switching inductive loads
(HARDWARE REQUIREMENT: CAR-TEST-SYSTEM 14)
- 7.1.11. EQ/IC 02: Resistance to pulses 3a and 3b
(HARDWARE REQUIREMENT: CAR-TEST-SYSTEM 14)
- 7.1.12. EQ/IC 03: Resistance to 5b pulses
(HARDWARE REQUIREMENT: Load dump generator LDS)
- 7.1.13. EQ/IC 04: Resistance to power supply micro interruptions
(HARDWARE REQUIREMENT: Electronic switch EMS 100 including option EMS.K.2.16)
- 7.1.14. EQ/IC 05: Resistance to pulses 4 BIS
(HARDWARE REQUIREMENT: Option OPT.24: programmable internal resistance of the LVA)
- 7.1.15. EQ/IC 12: Resistance to re-start pulse
(HARDWARE REQUIREMENT: Option OPT.24: programmable internal resistance of the LVA)
- 7.1.16. EQ/IC 13: Resistance to "voltage control" voltage pulse
(HARDWARE REQUIREMENT: Option OPT.24: programmable internal resistance of the LVA)
- 7.1.17. EQ/IC 06: Resistance to voltage ripples

7.3 EMC IMMUNITY TESTS (GENERAL CASE)

- 7.3.1. EQ/IC 07 Immunity to the transients on the signal lines
(HARDWARE REQUIREMENT: CAR-TEST-SYSTEM 14 with capacitive coupling clamp CDN 2012)

7.4 EMC EMISSION TESTS (GENERAL CASE)

- 7.4.1. EQ/MC 01 Measurement of switching noises

Testing according to Renault 36-00-808/--M (2012-07)

6.1 RESISTANCE TO ELECTRICAL DISTURBANCES TESTS

- 6.1.1. EQ/TE 01: Resistance to power supply voltages
- 6.1.2. EQ/TE 02: Resistance to slow decrease and increase power of supply voltages
- 6.1.3. EQ/TE 03: Re-initialisation test
- 6.1.4. EQ/TE 04: Resistance to non-usual power supply voltages
- 6.1.5. EQ/TE 05: Resistance to ground and positive supply voltages short circuit
(HARDWARE REQUIREMENT: Electronic switch EMS 100 including option EMS.K.2.16)
- 6.1.6. EQ/IC 01: Resistance to pulses 1 and 1bis and 2a
(HARDWARE REQUIREMENT: CAR-TEST-SYSTEM 14)
- 6.1.7. EQ/IC 02: Resistance to pulses 3a and 3b
(HARDWARE REQUIREMENT: CAR-TEST-SYSTEM 14)
- 6.1.8. EQ/IC 10: Resistance of inductive load connected circuits
(HARDWARE REQUIREMENT: CAR-TEST-SYSTEM 14)
- 6.1.9. EQ/IC 03: Resistance to pulses 5b
(HARDWARE REQUIREMENT: Load dump generator LDS)
- 6.1.10. EQ/IC 04: Resistance to power supply micro interruptions
(HARDWARE REQUIREMENT: Electronic switch EMS 100 including option EMS.K.2.16)
- 6.1.11. EQ/IC 05: Resistance to starting profile
- 6.1.12. EQ/IC 06: Resistance to on-board power system voltage ripples

6.2 IMMUNITY TO CONDUCTED DISTURBANCE TEST

- 6.2.1. EQ/IC 07: Immunity to signal line transients
(HARDWARE REQUIREMENT: CAR-TEST-SYSTEM 14 with capacitive coupling clamp CDN 2012)

Software module VW 80000 (S.AU.VW.80000)

Testing according to VW 80000 (2013-06/2017-10)

- E-01 Long-term overvoltage
- E-02 Transient overvoltage
- E-03 Transient undervoltage
- E-04 Jump start
- E-05 Load dump
- E-06 Component immunity to ripple on power supply leads
(**HARDWARE REQUIREMENT:** Option OPT.24: programmable internal resistance of the LVA)
- E-07 Slow decrease and increase of the supply voltage
- E-08 Slow decrease, quick increase of the supply voltage
- E-09 Reset behaviour
- E-10 Short interruptions
(**HARDWARE REQUIREMENT:** Electronic switch EMS 100)
- E-11 Start pulses / cranking profile
 - Test 1 - Cold start
 - Test 2 - Warm start
- E-12 Voltage curve with IGR
- E-13 Pin interruption
(**HARDWARE REQUIREMENT:** Electronic switch EMS 100 including Option EMS.SSW.1.16)
- E-14 Connector interruption
(**NOTE:** For this test E-14 the LVA system provides only the voltage source)
- E-15 Reverse polarity
(**HARDWARE REQUIREMENT:** Option OPT.24: programmable internal resistance of the LVA)
- E-16 Ground offset
(**HARDWARE REQUIREMENT:** Electronic switch EMS 100 including option EMS.K.2.16 and an additional amplifier or an external battery)
- E-17 Short circuit in signal circuit and load circuits
(**HARDWARE REQUIREMENT:** Electronic switch EMS 100 including option EMS.K.2.16)
- E-19 Closed circuit current
(**HARDWARE REQUIREMENT:** External current measurement unit)
- E-21 Backfeeds
(**HARDWARE REQUIREMENT:** Electronic switch EMS 100)

Software module VW TL81000 (S.AU.VW.TL81000)

Testing according to VW TL 80101 (2016-02)

- 3.4.2.1 Test pulse 1 (for 12/24/42/48V)
- 3.4.2.2 Test pulse 2 (for 12/24/42/48V)
- 3.4.2.3 Test pulse 3a / 3b (for 12/24/42/48V)
- 3.4.2.4 Test pulse 5b (for 42/48V)
- 3.4.2.5 Test pulse 6 (for 12/24/42/48V)

LVA 4-Quadrant Amplifier 1000

AUTOMOTIVE SUPPLY SIMULATION
AT IT'S BEST



Example: LVA 1000 Front panel

- ✓ Extremely low harmonic distortion - even under very non-linear load conditions
- ✓ Very fast slew rate > 10V/μs
- ✓ Operates from DC up to 50kHz large signal bandwidth (-3dB)
- ✓ Small signal bandwidth up to 300kHz
- ✓ High short-term overload characteristic (for 30s)
- ✓ Very high peak-load ability (up to 200ms)
- ✓ Programmable internal resistance 0 ... 200mΩ
- ✓ Sink operation mode can be disabled
- ✓ Touch panel operation 7" 800x480
- ✓ Optional overvoltage protection device OPD

The relating standards:

ISO 7637-2/-3

ISO 16750-2

ISO 21848

LV 124

VDA 320 (LV 148)

SAE J 1113-11

BMW GS 95002

BMW GS 95024-2-2

BMW GS 95026

Ford FMC 1278

General Motors GMW 3097

JLR-EMC-CSv1.2

Mercedes MBN LV124-1

PSA B21 7110

Renault 36-00-808/--M

VW TL 81000

VW 80000

VW 82148

THE REFERENCE SOURCE FOR AUTOMOTIVE APPLICATIONS

AMPLIFIER CHARACTERISTIC – OUTPUT CURRENT CAPABILITY

20V Range continuous current I_{cont} : **LVA1000**

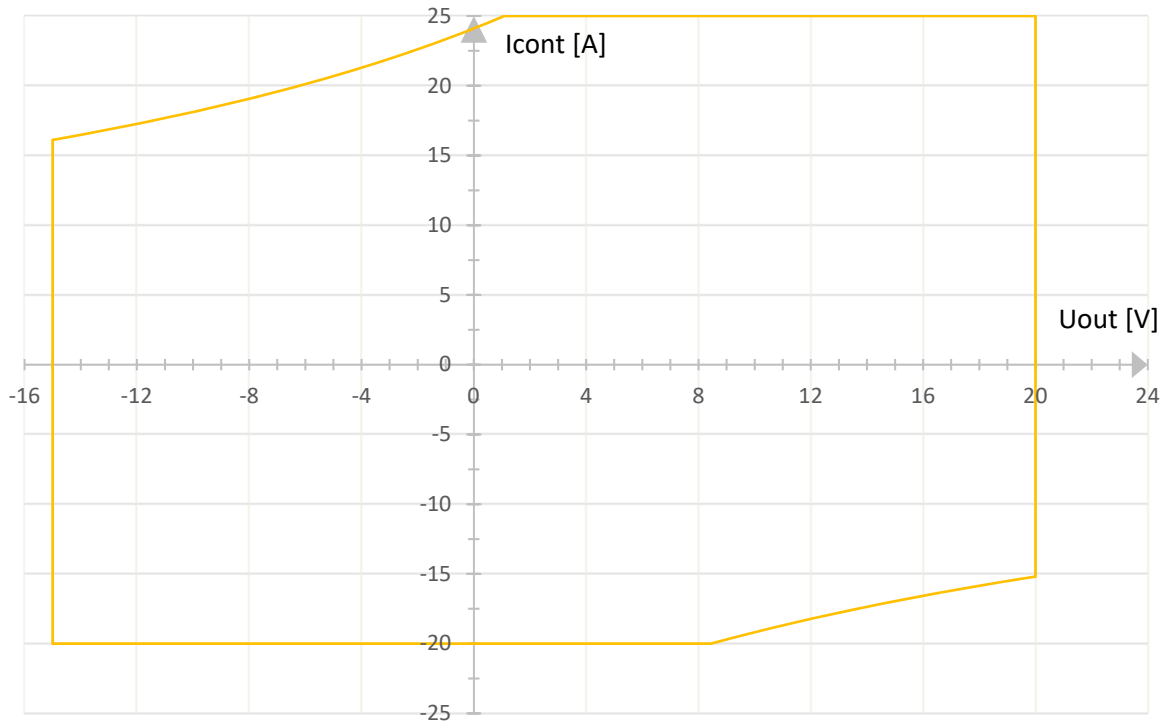

20V Range short-time current I_{short} : **LVA1000**

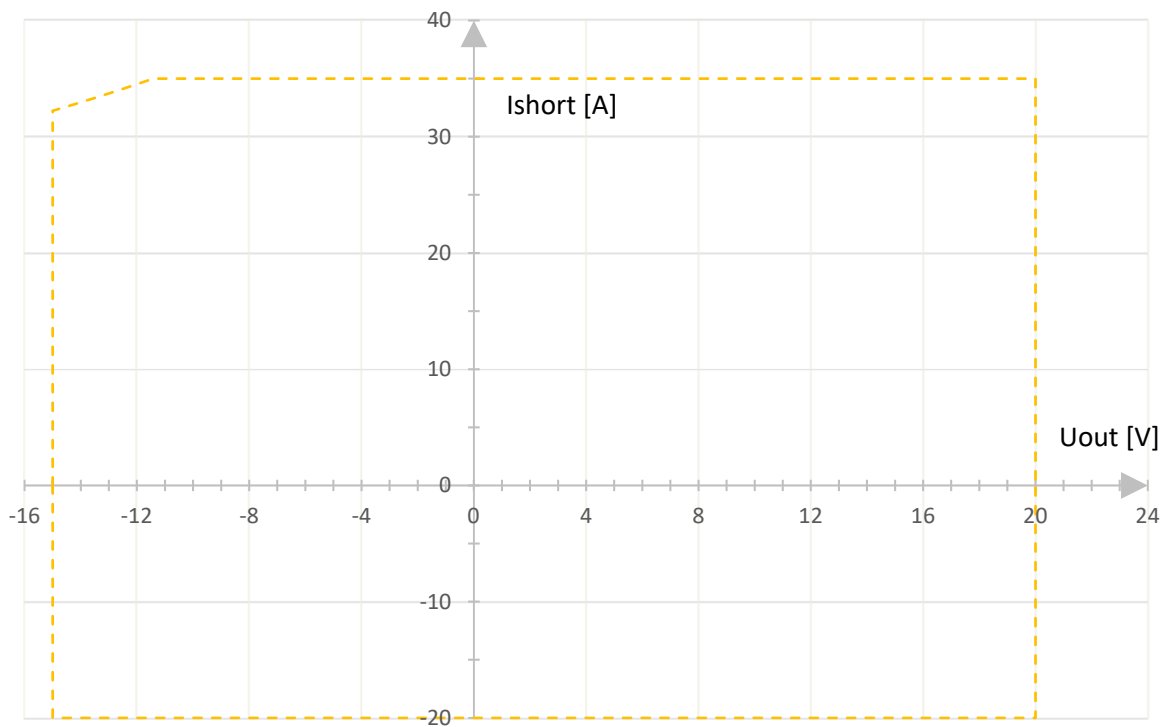

AMPLIFIER CHARACTERISTIC – OUTPUT CURRENT CAPABILITY

36V Range continuous current I_{cont} : **LVA1000**

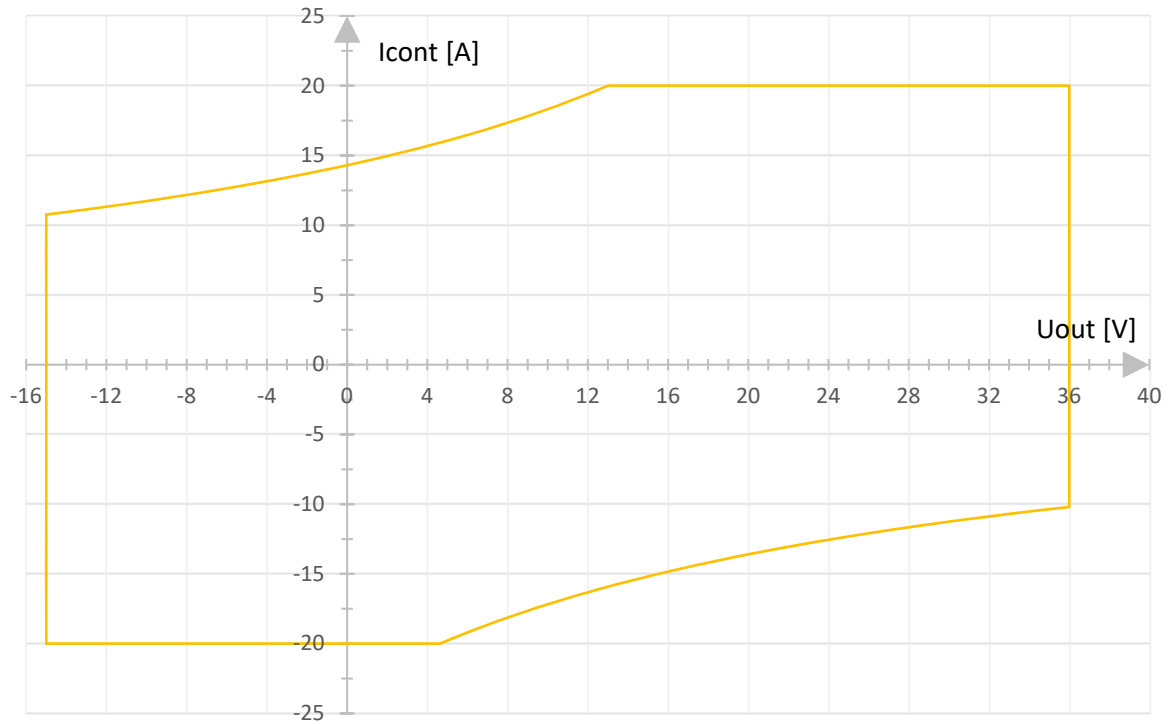

36V Range short-time current I_{short} : **LVA1000**

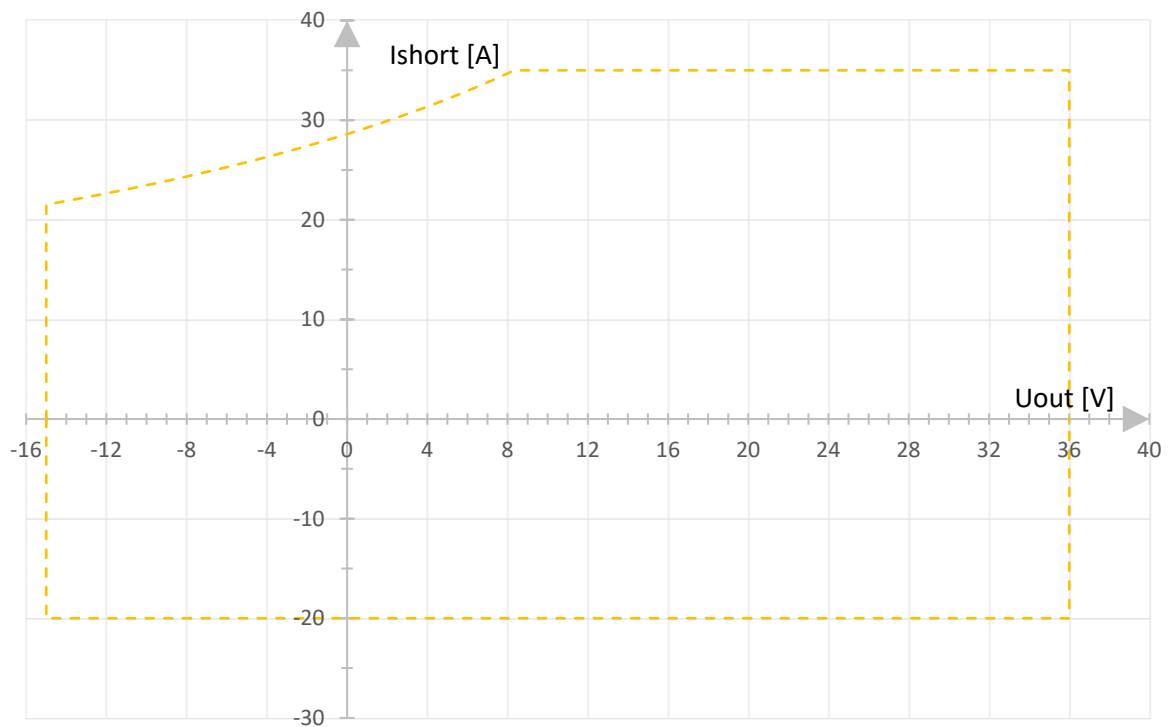

AMPLIFIER CHARACTERISTIC – OUTPUT CURRENT CAPABILITY

54V Range continuous current I_{cont} : LVA1000

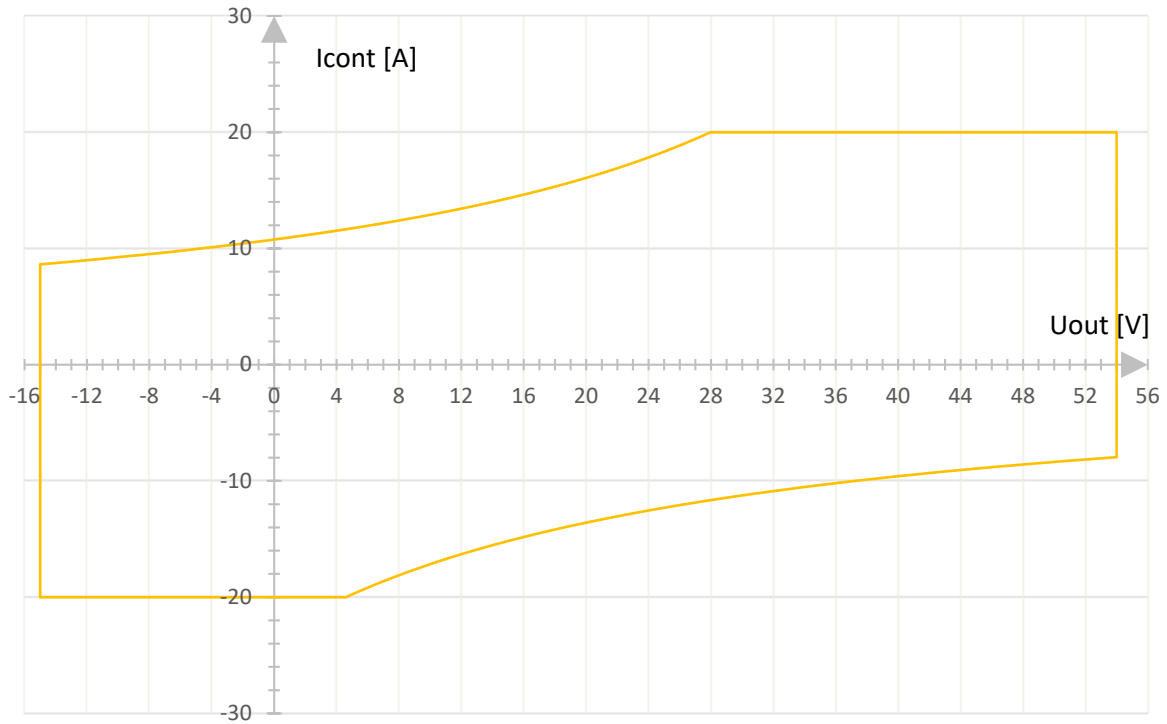

54V Range short-time current I_{short} : LVA1000

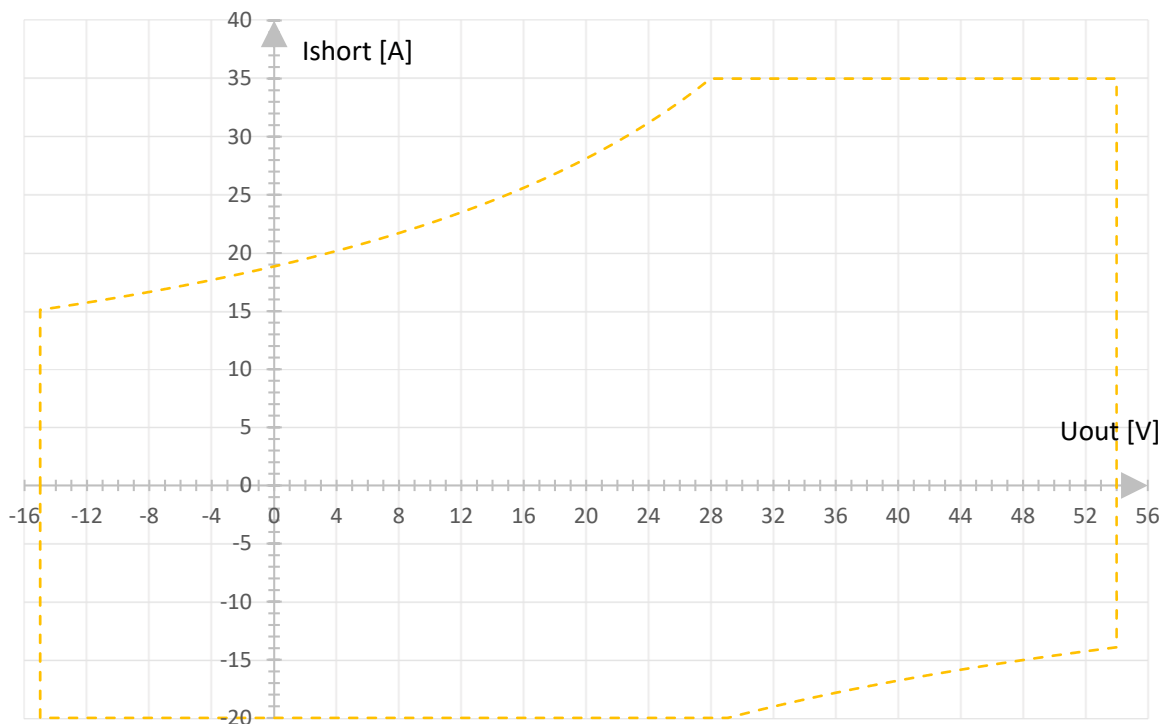

AMPLIFIER CHARACTERISTIC – OUTPUT CURRENT CAPABILITY

70V Range continuous current I_{cont} : **LVA1000**

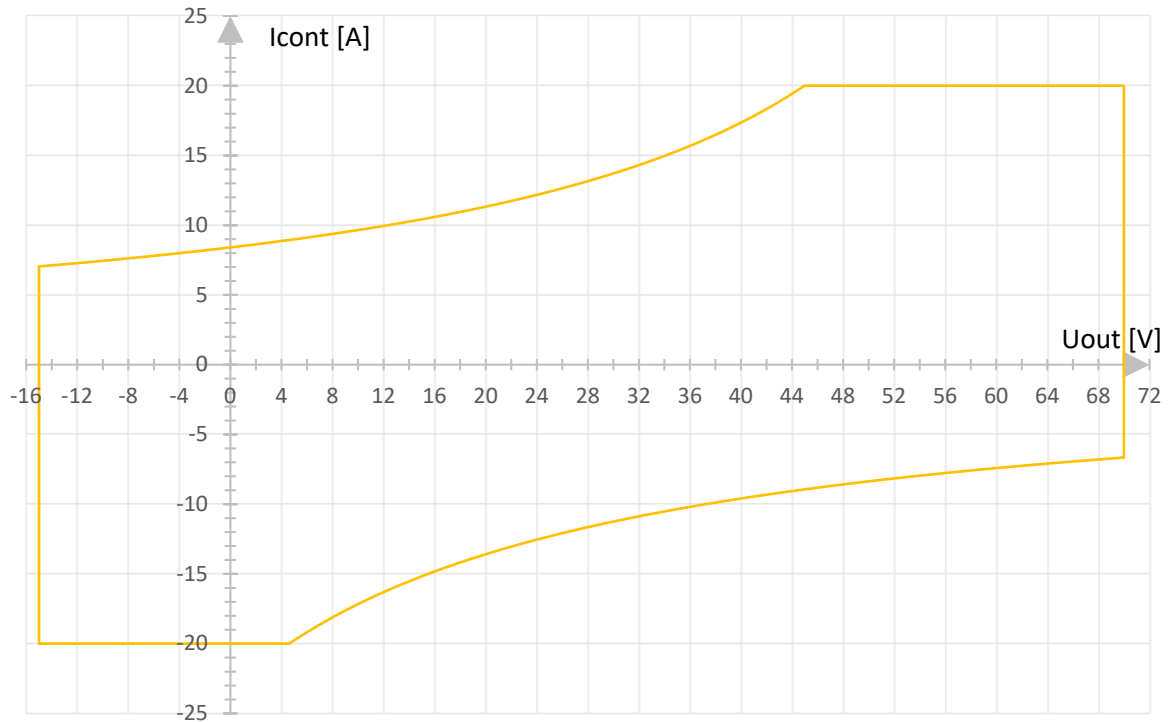

70V Range short-time current I_{short} : **LVA1000**

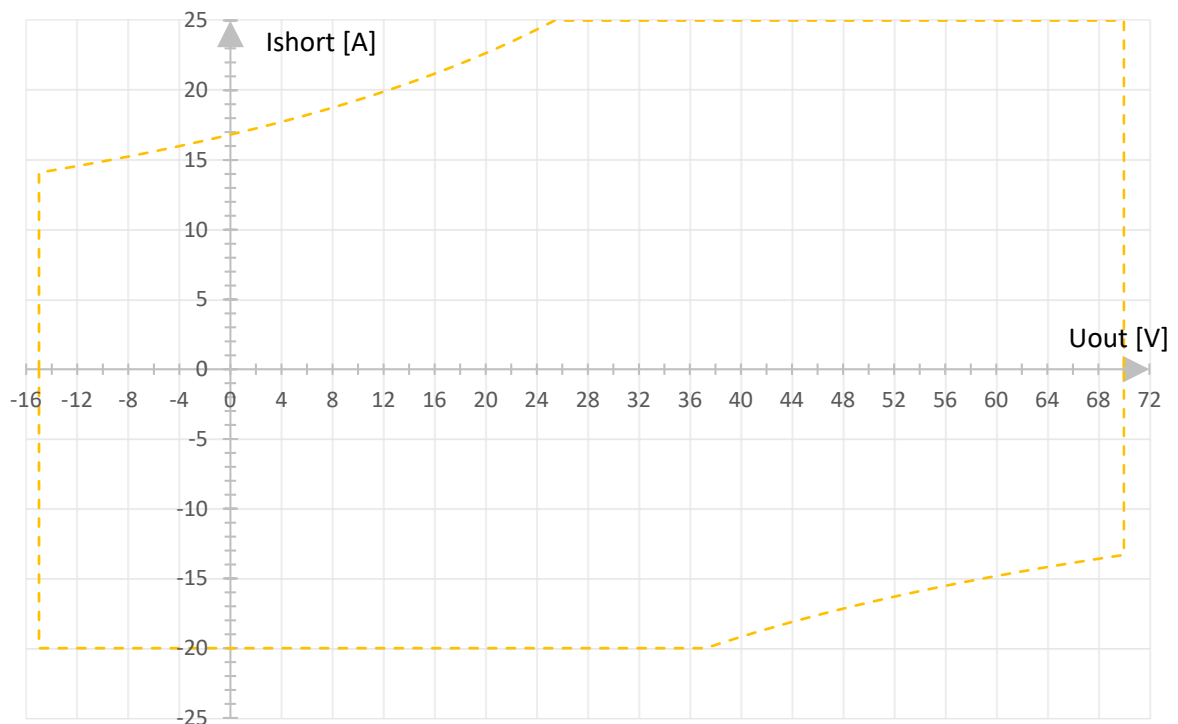

TECHNICAL DATA

Max. peak current capability (up to 200ms)		35A _p	
Continuous and short-time output current capability		<i>range depending (see diagrams)</i>	
Nominal voltage ranges		U_1 : -15V _{DC} ... 20V _{DC} U_2 : -15V _{DC} ... 36V _{DC} U_3 : -15V _{DC} ... 54V _{DC} U_4 : -15V _{DC} ... 70V _{DC}	
Digital instrument	Voltage range	Autoranging (20/40/80V _{DC} Ranges)	
	Current range	12.5A / 25A / 50A / 100A	
Accuracy Voltage		DC: 1000ppm of reading / 200ppm of range value	
Accuracy Current		DC: 2000ppm of reading / 400ppm of range value	
Protection circuits		Overload / Short circuit / Overtemperature	
Interface		Ethernet	
Supply	Power Supply	230V (±10%, 50/60Hz)	
	Protection	10A	
	Connector type	Safety plug	
Housing		19"-Desktop unit, colour light grey (RAL 7035)	
Dimensions (mm)		5U: 222x483x700	
Weight		approx. 70kg	
General	Voltage adjustment	Touch panel / Remote / External input	
	Load regulation: 0 ... nominal load	max. 0.2%, typ. <0.1%	
	Internal resistance compensation	DC ... 1kHz (-3dB)	
	Frequency range (no load)	DC ... 50kHz large signal bandwidth (-3dB) DC ... 300kHz small signal bandwidth (10% of range, -3dB)	
	Noise at output	<5mV _{rms} (<100kHz), <10mV _{rms} (100kHz - 20MHz)	
Slew rate		SR: >10V/μs	
Adjustable current limitation		Accuracy see current measurement unit response time < 20μs	
Floating output		<i>Max. voltage between earth and amplifier output ground:</i> 300V _{rms}	
Internal control oscillator	Type	4-channel synthesizer	
	Wave form	DC, Sine, Rectangle, Triangle, DC Offset, Arbitrary	
	Amplitude resolution	17Bit	
	Frequency range	DC ... 1MHz	
	Frequency resolution	1μHz	
	Frequency accuracy	25ppm	
	Memory depth	1MSample	
	Synth functions	ADD, AM, FM, PM	
	Sequence memory	1024 steps	
	External floating input	V: 0 ... ±5V _{DC} (Input resistance: 11.5 kΩ)	
	Digital I/O	8 digital inputs +5V _{DC} ... +24V _{DC} 8 digital outputs +5V _{DC} , I _L =40mA (external V _{CC} input: +5V _{DC} ... +24V _{DC} , I _L =500mA)	

Monitoring unit ²⁾	voltage	current
<i>Max. output</i>		±10V _p
<i>Scaling factor (adjustable)</i>	0.2 ... 1000	0.1 ... 1000
<i>Bandwidth</i>	300kHz	200kHz
<i>Accuracy</i>		0.3%
<i>Noise of ADC measurement</i>	<20mV _{rms} (DC ... 300kHz)	<1.5mA _{rms} (DC ... 300kHz)
<i>Noise DAC output</i>	<0.2mV _{rms} (DC ... 300kHz)	
<i>Delay time</i>	<1µs	
<i>Output impedance</i>	220Ohm	
<i>Isolation</i>	earth / remaining electronics / each other	
<i>Protection</i>	short circuit	
Insulation resistance	>1MOhm	
Withstand voltage	>2000V _{DC}	
Ambient temperature	0°C up to 40°C	
Relative Humidity (non-condensing)	max. 80% for temperatures <31°C, decreasing linearly to 50% at 40°C	
System of protection	IP20	

LVA 1000 AMPLIFIER – OPTIONS

OPT.01	IEEE 488 Interface
OPT.02	RS 232 Interface (instead of IEEE 488 Interface)
OPT.05	Output voltage and current monitor (electrically isolated) Probe ratio free adjustable
NT.11.70S.1K	Symmetrical voltage range (for magnetic field tests) V:0 ... ± 70V _{DC} / I _{DC,cont} :20 A _{DC} / I _{DC,short} :25 A _{DC}
OPT.24.01	Programmable internal resistance R:0mΩ ... 200.0mΩ / Accuracy: ±1% of range
OPT.25.01	Constant current mode
OPD.01	Overvoltage Protection Device

The LVA is also available as LVA 2500, LVA 5000 and LVA 7500 version.

LVA 4-Quadrant Amplifier 2500

**AUTOMOTIVE SUPPLY SIMULATION
AT IT'S BEST**



Example: LVA 1000 Front panel

- ✓ Extremely low harmonic distortion - even under very non-linear load conditions
- ✓ Very fast slew rate > 20V/μs
- ✓ Operates from DC up to 100kHz large signal bandwidth (-3dB)
- ✓ Small signal bandwidth up to 300kHz
- ✓ High short-term overload characteristic (for 30s)
- ✓ Very high peak-load ability (up to 200ms)
- ✓ Programmable internal resistance 0 ... 200mΩ
- ✓ Sink operation mode can be disabled
- ✓ Touch panel operation 7" 800x480
- ✓ Optional overvoltage protection device OPD

The relating standards:

ISO 7637-2/-3

ISO 16750-2

ISO 21848

LV 124

VDA 320 (LV 148)

SAE J 1113-11

BMW GS 95002

BMW GS 95003-2

BMW GS 95024-2-2

BMW GS 95026

DaimlerChrysler DO-10615

Fiat 9.90110

Ford FMC 1278

General Motors GMW 3097

JLR-EMC-CSv1.2

Mercedes-Benz MBN

LV124-1

PSA B21 7110

Renault 36-00-808/--M

VW TL 81000

VW 80000

VW 82148

THE REFERENCE SOURCE FOR AUTOMOTIVE APPLICATIONS

AMPLIFIER CHARACTERISTIC – OUTPUT CURRENT CAPABILITY

20V Range continuous current I_{cont} : LVA2500

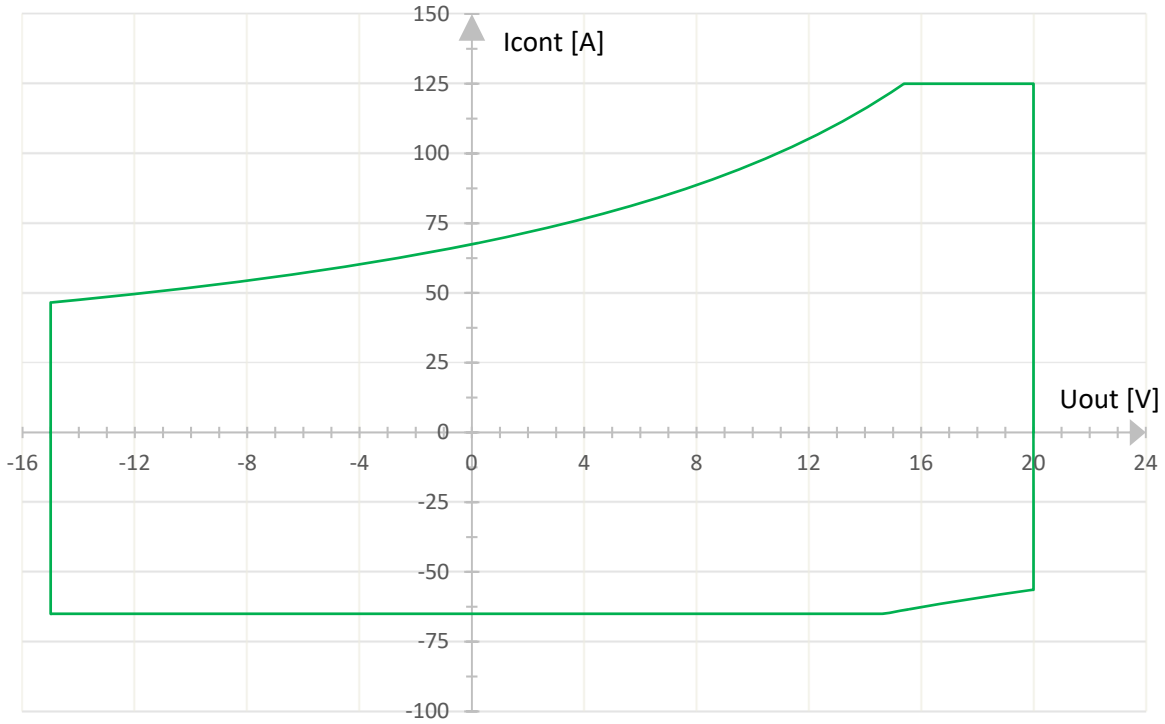

20V Range short-time current I_{short} : LVA2500

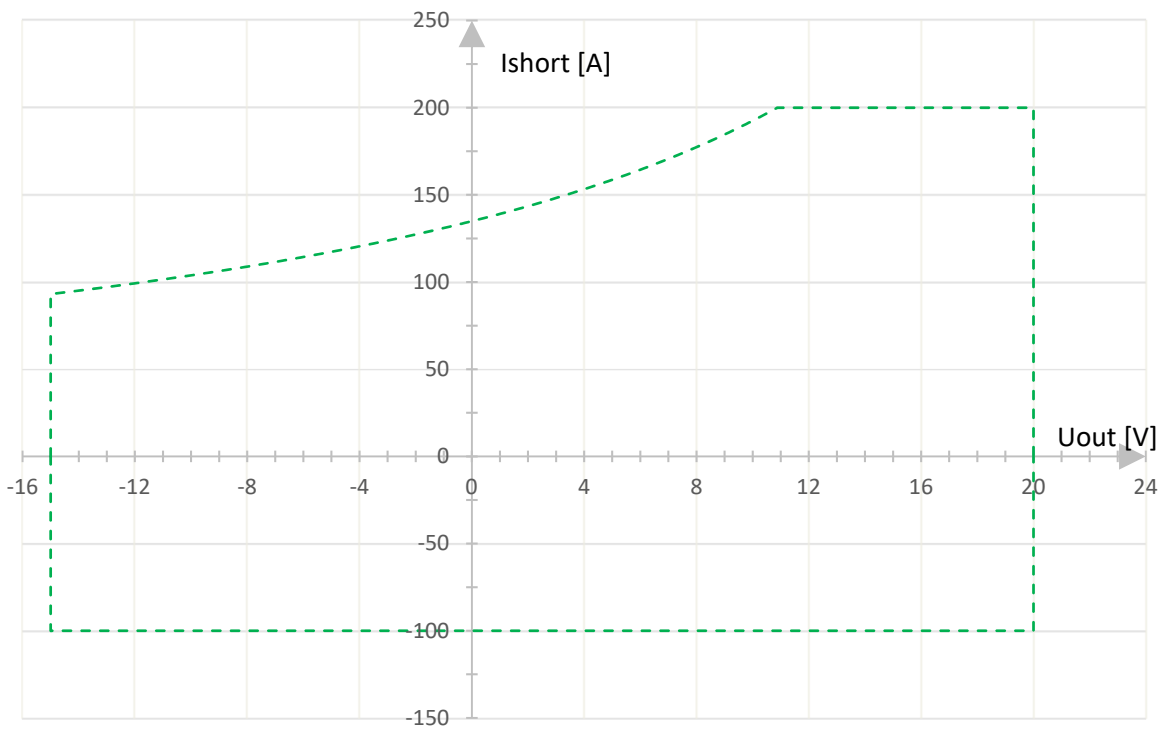

AMPLIFIER CHARACTERISTIC – OUTPUT CURRENT CAPABILITY

36V Range continuous current I_{cont} : LVA2500

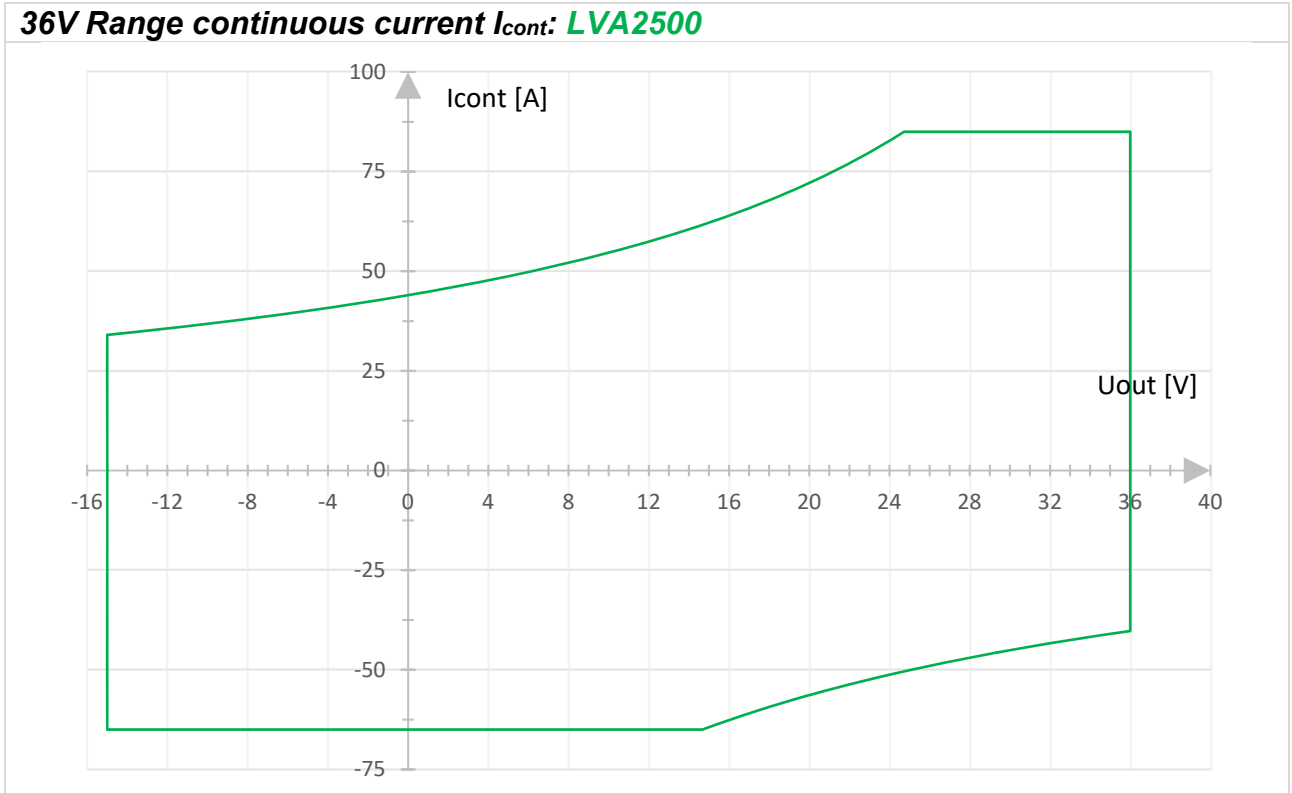

36V Range short-time current I_{short} : LVA2500

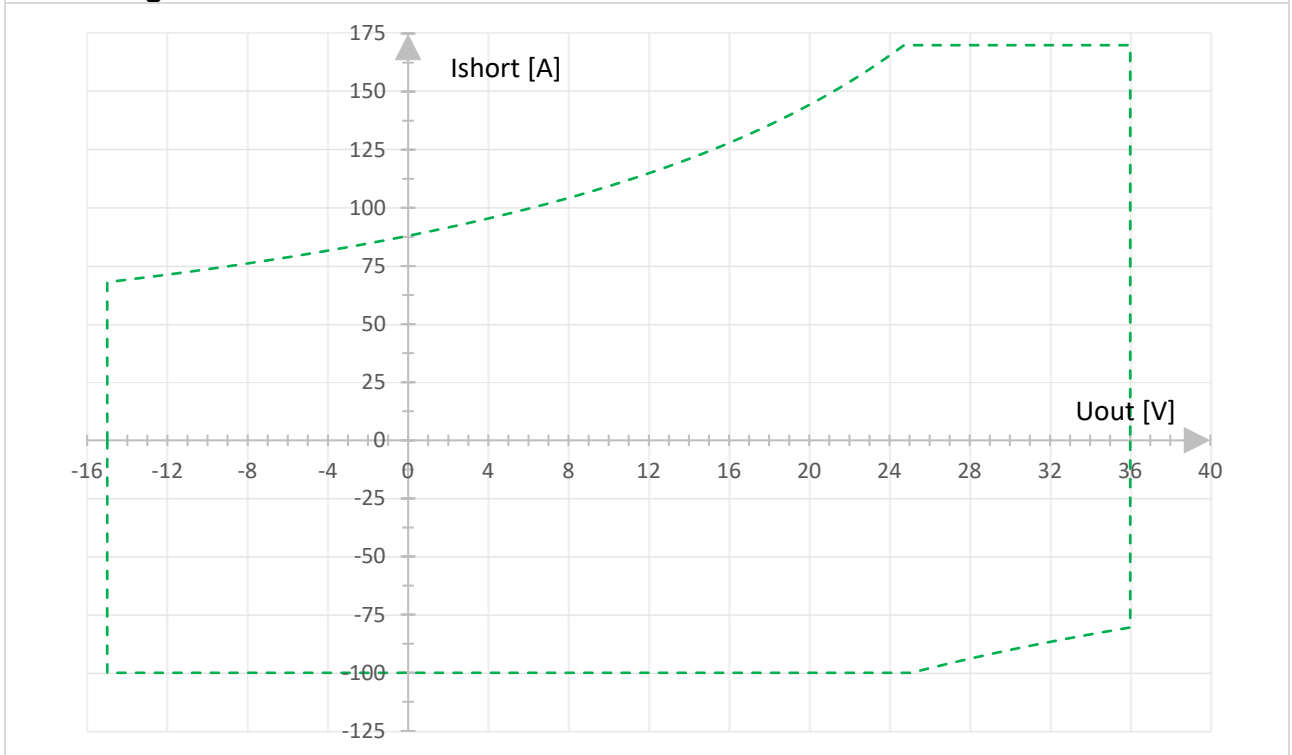

AMPLIFIER CHARACTERISTIC – OUTPUT CURRENT CAPABILITY

54V Range continuous current I_{cont} : LVA2500

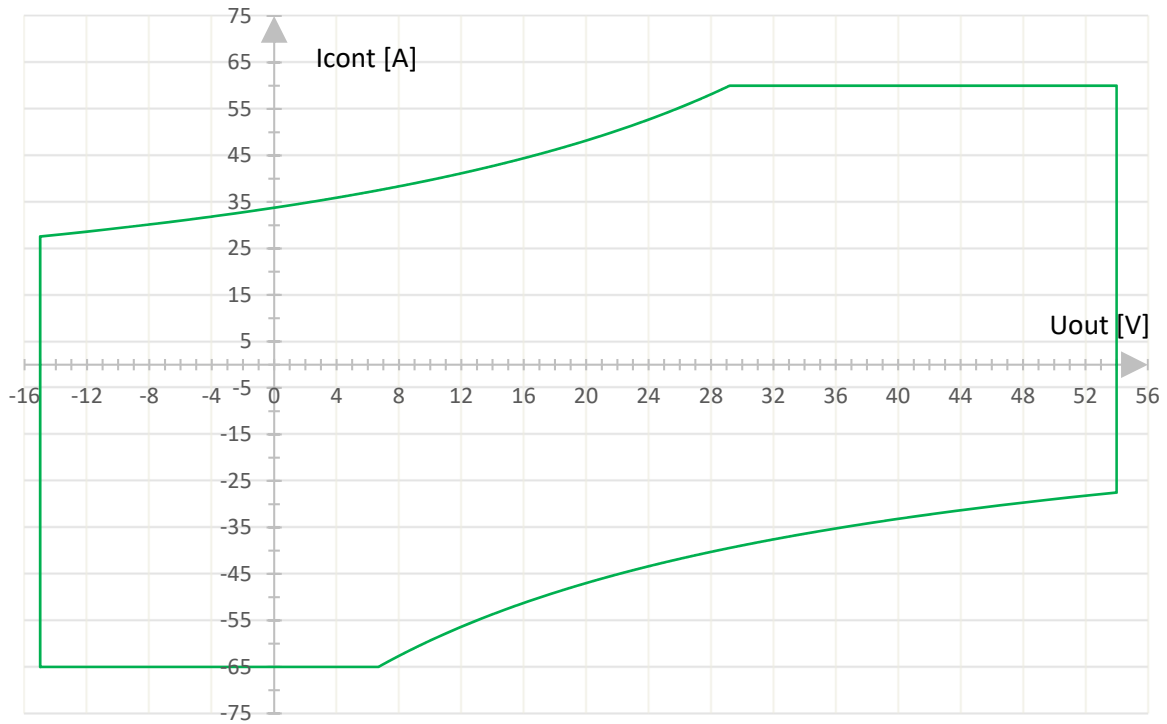

54V Range short-time current I_{short} : LVA2500

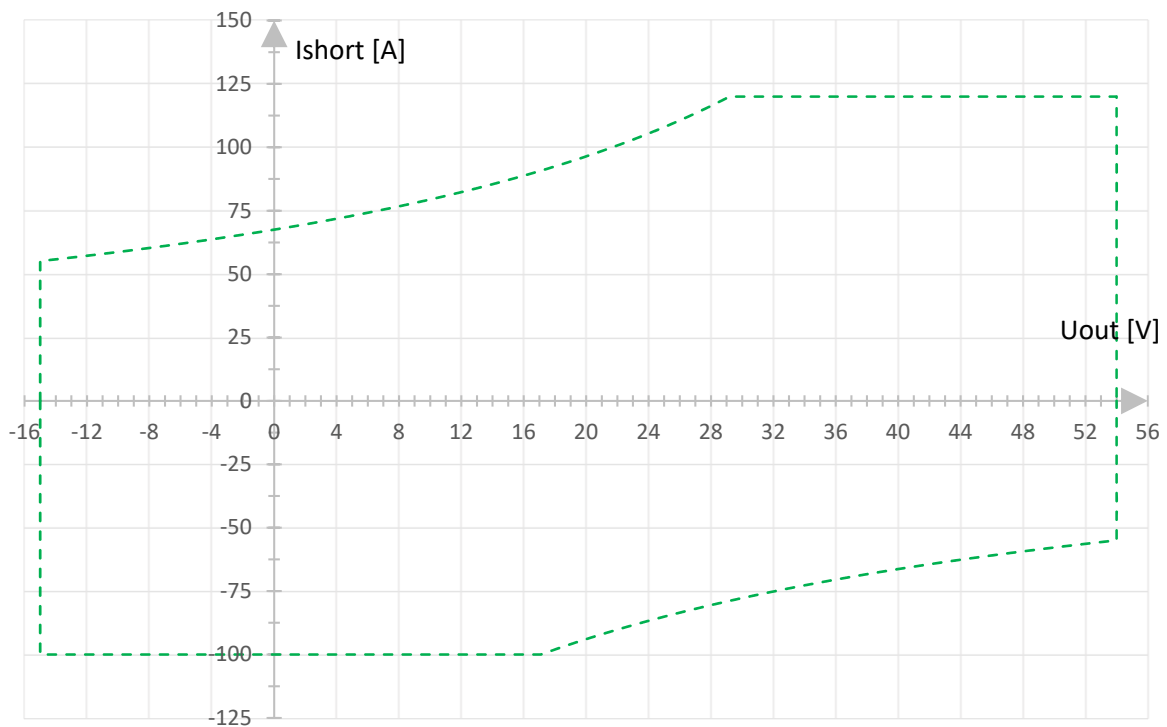

AMPLIFIER CHARACTERISTIC – OUTPUT CURRENT CAPABILITY

70V Range continuous current I_{cont} : **LVA2500**

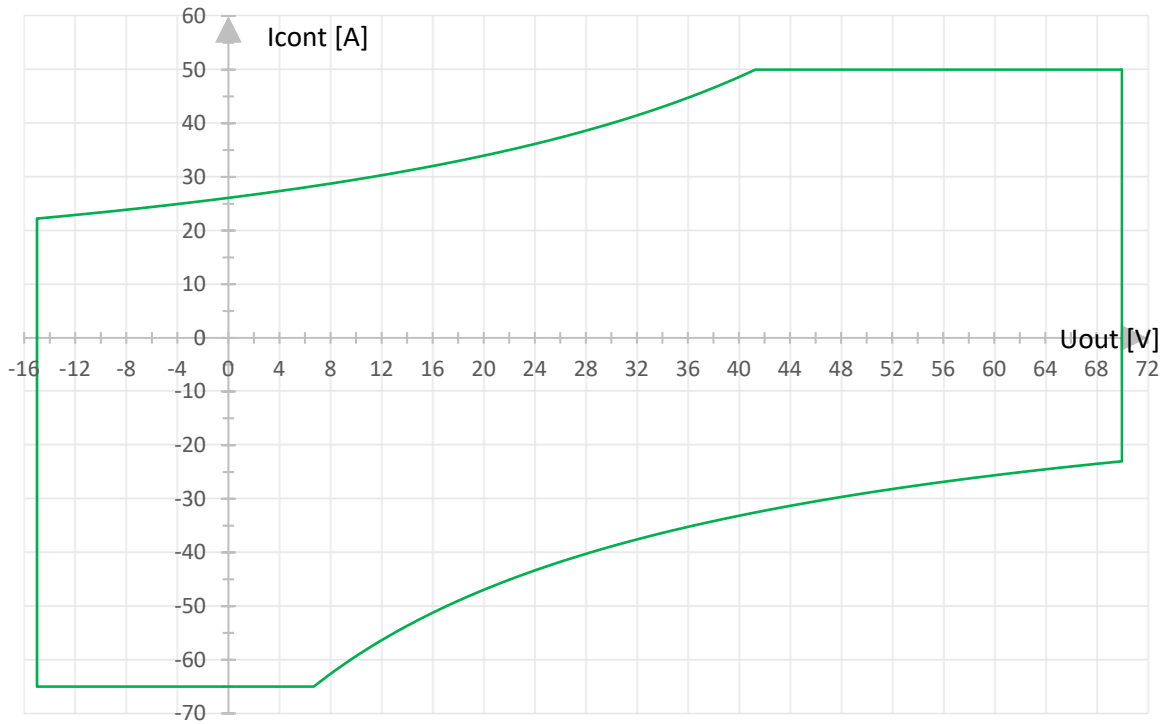

70V Range short-time current I_{short} : **LVA2500**

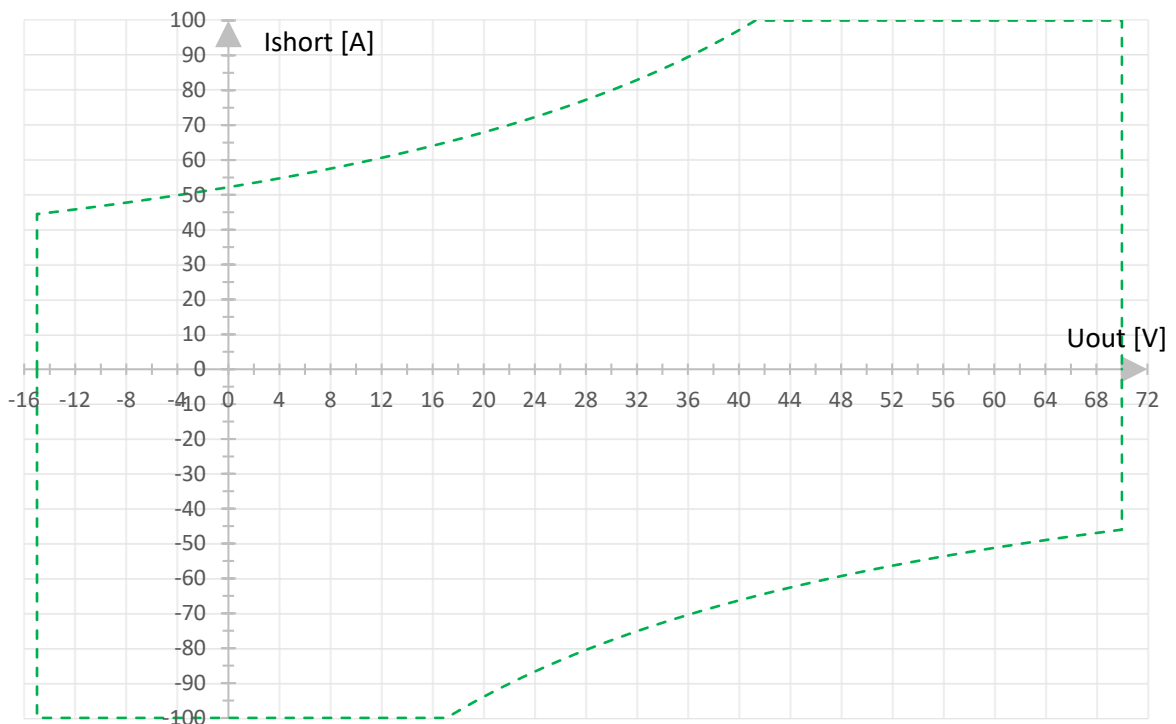

TECHNICAL DATA

Max. peak current capability (up to 200ms)		300A _p
Continuous and short-time output current capability		range depending see diagrams
Nominal voltage ranges		U ₁ : -15V _{DC} ... 20V _{DC} U ₂ : -15V _{DC} ... 36V _{DC} U ₃ : -15V _{DC} ... 54V _{DC} U ₄ : -15V _{DC} ... 70V _{DC}
Digital instrument	Voltage range	Autoranging (20/40/80V _{DC} Ranges)
	Current range	37.5A / 75A / 150A / 300A
Accuracy Voltage		DC: 1000ppm of reading / 200ppm of range value
Accuracy Current		DC: 2000ppm of reading / 400ppm of range value
Supply	Power Supply	230V/400V (±10%, 50/60Hz)
	Protection	16A
	Connector type	CEE
Housing		19"-rack, colour light grey (RAL 7035)
Dimensions (mm)		LVA: 222x483x700 5U Power Supply: 267x483x700 6U
Weight		LVA integrated in 24" rack: approx. 40kg LVA integrated in 37" rack: approx. 120kg
General	Voltage adjustment	Touch panel / Remote / External input
	Load regulation: 0 ... nominal load	max. 0.2%, typ. <0.1%
	Internal resistance compensation	DC ... 1kHz (-3dB)
	Frequency range (no load)	DC ... 100kHz large signal bandwidth (-3dB) DC ... 300kHz small signal bandwidth (10% of range, -3dB)
	Noise at output	<5mV _{rms} (<100kHz), <10mV _{rms} (100kHz - 20MHz)
	Slew rate	SR: >20V/μs
	Adjustable current limitation	Accuracy see current measurement unit response time < 20μs
Floating output		Max. voltage between earth and amplifier output ground: 300V _{rms}
Internal control oscillator	Type	4-channel synthesizer
	Wave form	DC, Sine, Rectangle, Triangle, DC Offset, Arbitrary
	Amplitude resolution	17Bit
	Frequency range	DC ... 1MHz
	Frequency resolution	1μHz
	Frequency accuracy	25ppm
	Memory depth	1MSample
	Synth functions	ADD, AM, FM, PM
	Sequence memory	1024 steps
	External floating input	V: 0 ... ±5V _{DC} (Input resistance: 11.5 kΩ)
	Digital I/O	8 digital inputs +5V _{DC} ... +24V _{DC} 8 digital outputs +5V _{DC} , I _L =40mA (external V _{CC} input: +5V _{DC} ... +24V _{DC} , I _L =500mA)

Monitoring unit ²⁾	voltage	current
<i>Max. output</i>		±10V _p
<i>Scaling factor (adjustable)</i>	0.2 ... 1000	0.1 ... 1000
<i>Bandwidth</i>	300kHz	200kHz
<i>Accuracy</i>		0.3%
<i>Noise of ADC measurement</i>	<20mV _{rms} (DC ... 300kHz)	<1.5mA _{rms} (DC ... 300kHz)
<i>Noise DAC output</i>	<0.2mV _{rms} (DC ... 300kHz)	
<i>Delay time</i>	<1µs	
<i>Output impedance</i>	220Ohm	
<i>Isolation</i>	earth / remaining electronics / each other	
<i>Protection</i>	short circuit	
Insulation resistance	>1MOhm	
Withstand voltage	>2000V _{DC}	
Ambient temperature	0°C up to 40°C	
Relative Humidity (non-condensing)	max. 80% for temperatures <31°C, decreasing linearly to 50% at 40°C	
System of protection	IP20	

LVA 2500 AMPLIFIER – OPTIONS

OPT.01	IEEE 488 Interface
OPT.02	RS 232 Interface (instead of IEEE 488 Interface)
OPT.05	Output voltage and current monitor (electrically isolated) Probe ratio free adjustable
NT.11.70S.2K5	Symmetrical voltage range (for magnetic field tests) V:0 ... ± 70V _{DC} / I _{DC,cont} :20 A _{DC} / I _{DC,short} :25 A _{DC}
OPT.24.02	Programmable internal resistance R:0mΩ ... 200.0mΩ / Accuracy: ±1% of range
OPT.25.02	Constant current mode
OPD.02	Overvoltage Protection Device

The LVA is also available as LVA 1000, LVA 5000 and LVA 7500 version.

LVA 4-Quadrant Amplifier 5000

AUTOMOTIVE SUPPLY SIMULATION
AT IT'S BEST



Example: LVA 1000 Front panel

- ✓ Extremely low harmonic distortion - even under very non-linear load conditions
- ✓ Very fast slew rate > 20V/μs
- ✓ Operates from DC up to 100kHz
large signal bandwidth (-3dB)
- ✓ Small signal bandwidth up to 300kHz
- ✓ High short-term overload characteristic (for 30s)
- ✓ Very high peak-load ability (up to 200ms)
- ✓ Programmable internal resistance 0 ... 200mΩ
- ✓ Sink operation mode can be disabled
- ✓ Touch panel operation 7" 800x480
- ✓ Optional overvoltage protection device OPD

The relating standards:

ISO 7637-2/-3

ISO 16750-2

ISO 21848

LV 124

VDA 320 (LV 148)

SAE J 1113-11

BMW GS 95002

BMW GS 95003-2

BMW GS 95024-2-2

BMW GS 95026

DaimlerChrysler DO-10615

Fiat 9.90110

Ford FMC 1278

General Motors GMW 3097

JLR-EMC-CSv1.2

Mercedes-Benz MBN

LV124-1

PSA B21 7110

Renault 36-00-808/--M

VW TL 81000

VW 80000

VW 82148

THE REFERENCE SOURCE FOR AUTOMOTIVE APPLICATIONS

AMPLIFIER CHARACTERISTIC – OUTPUT CURRENT CAPABILITY

20V Range continuous current I_{cont} : **LVA5000**

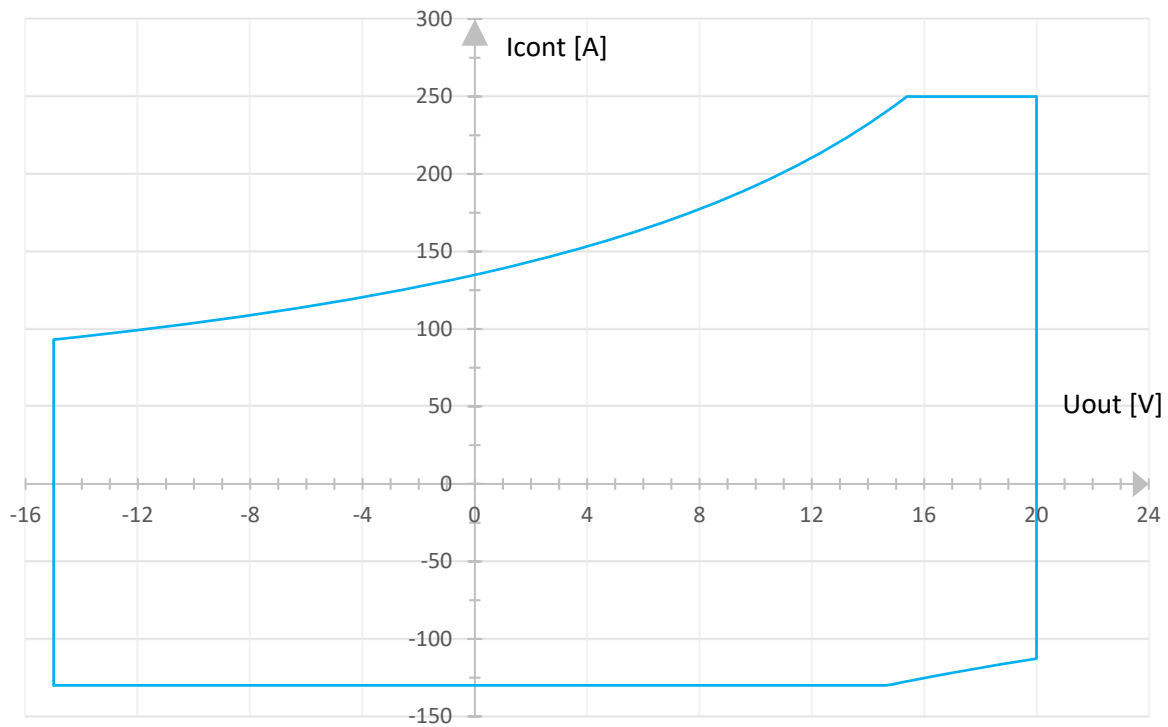

20V Range short-time current I_{short} : **LVA5000**

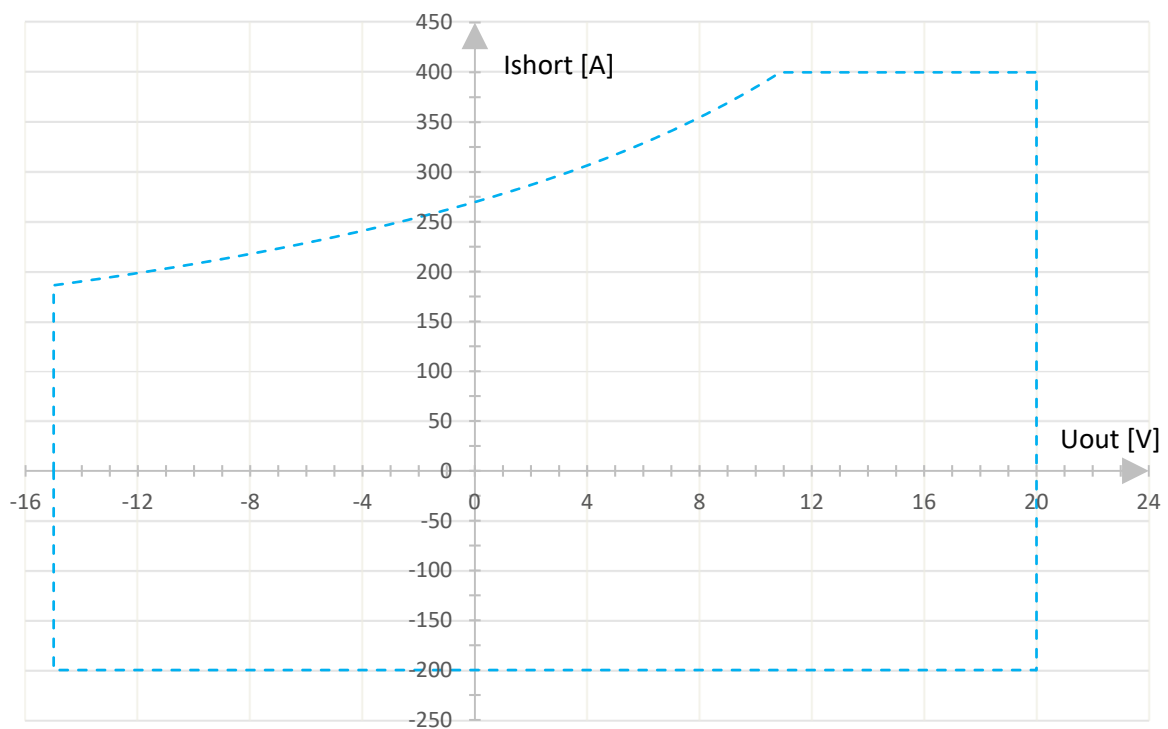

AMPLIFIER CHARACTERISTIC – OUTPUT CURRENT CAPABILITY

36V Range continuous current I_{cont} : LVA5000

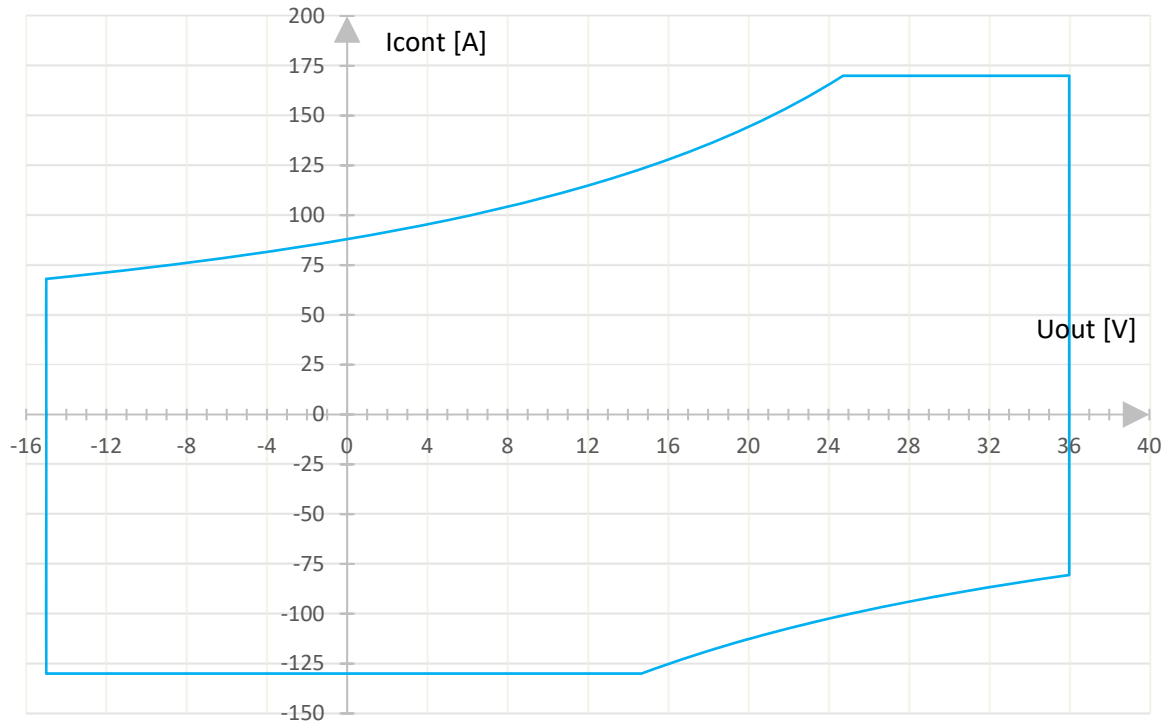

36V Range short-time current I_{short} : LVA5000

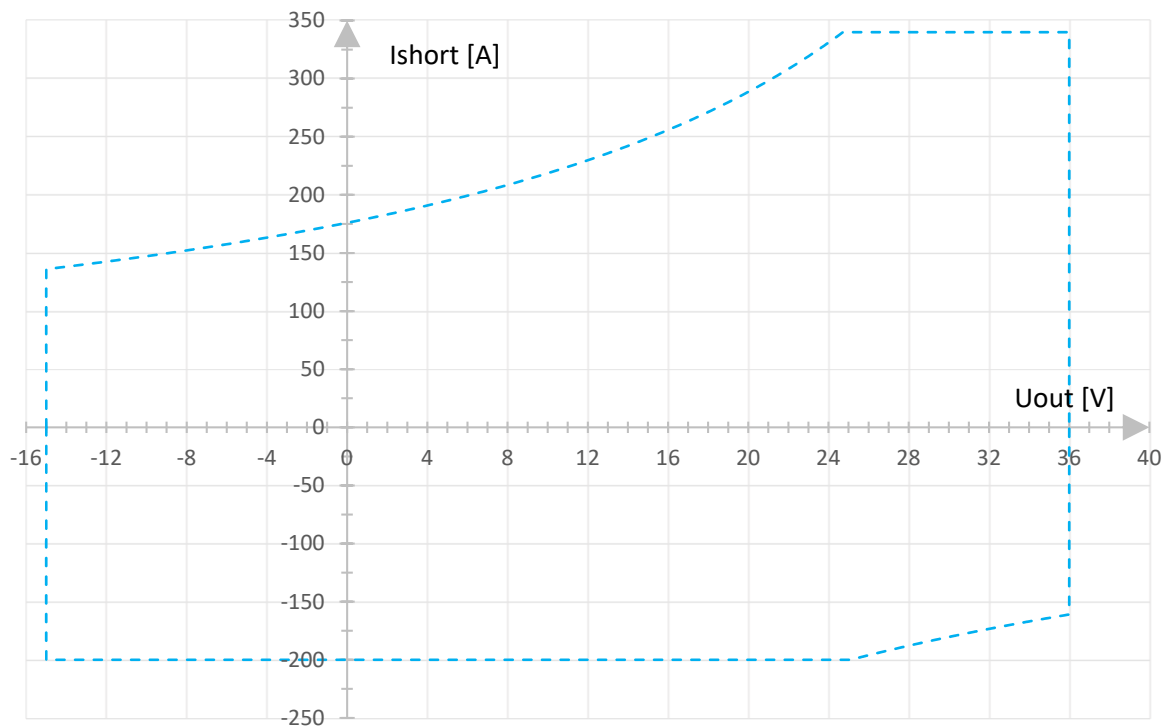

AMPLIFIER CHARACTERISTIC – OUTPUT CURRENT CAPABILITY

54V Range continuous current I_{cont} : LVA5000

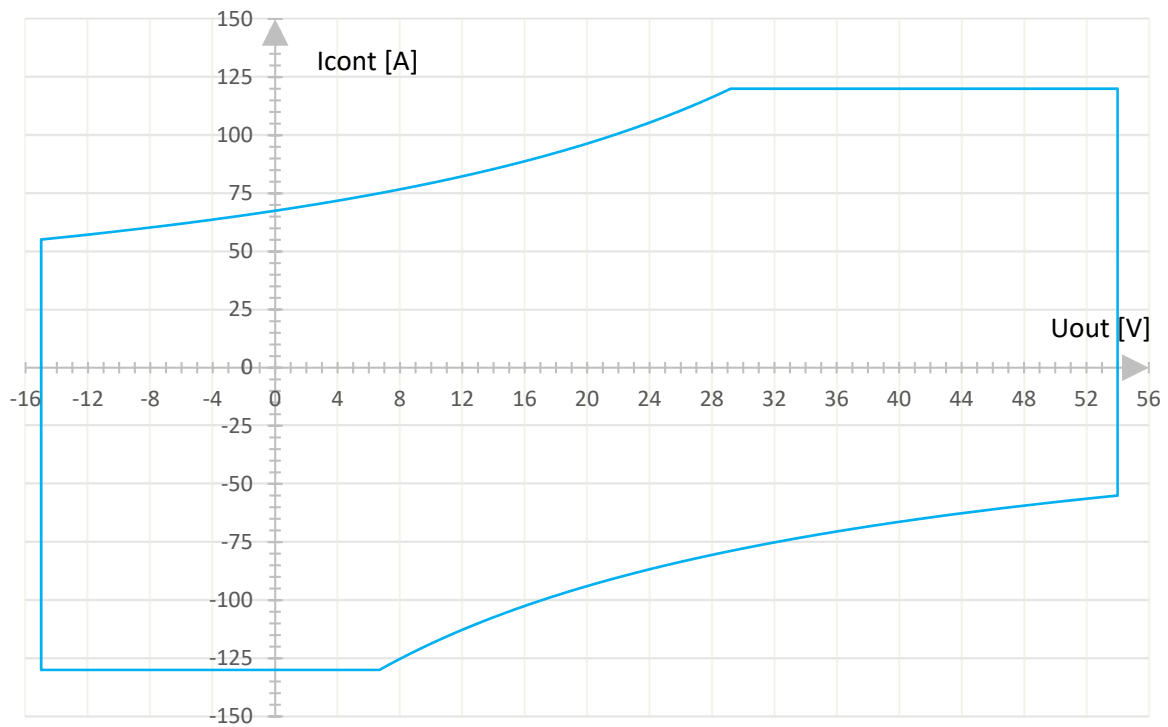

54V Range short-time current I_{short} : LVA5000

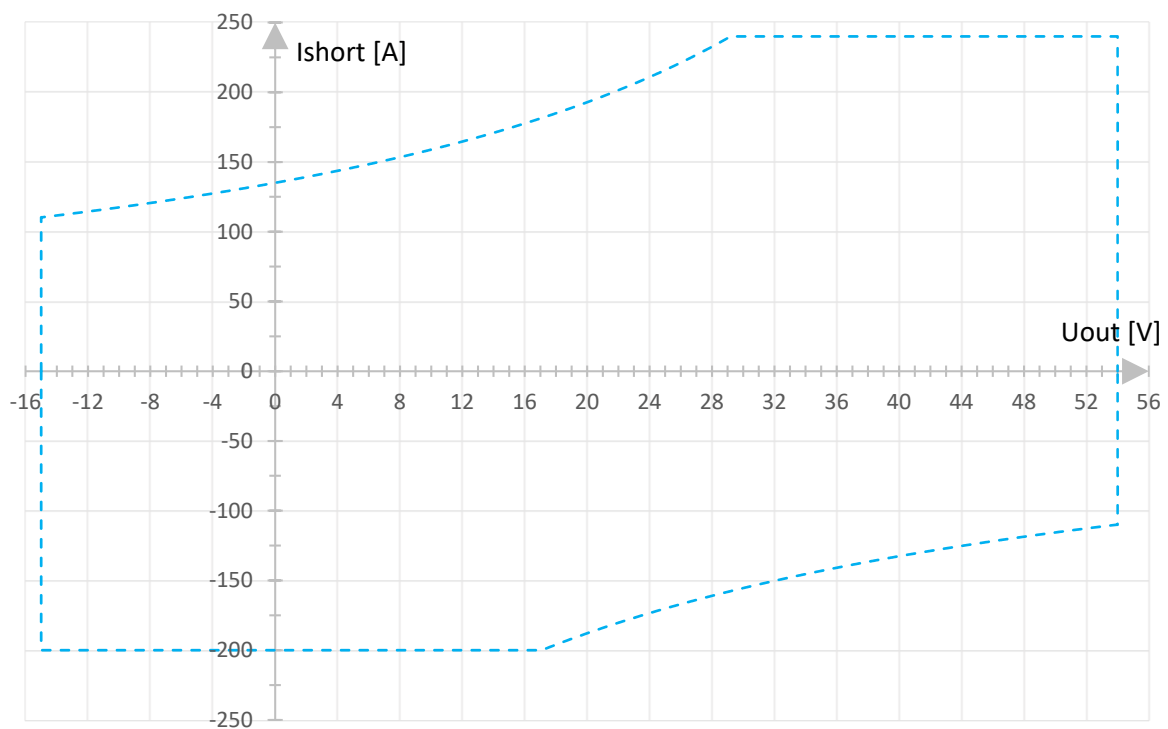

AMPLIFIER CHARACTERISTIC – OUTPUT CURRENT CAPABILITY

70V Range continuous current I_{cont} : **LVA5000**

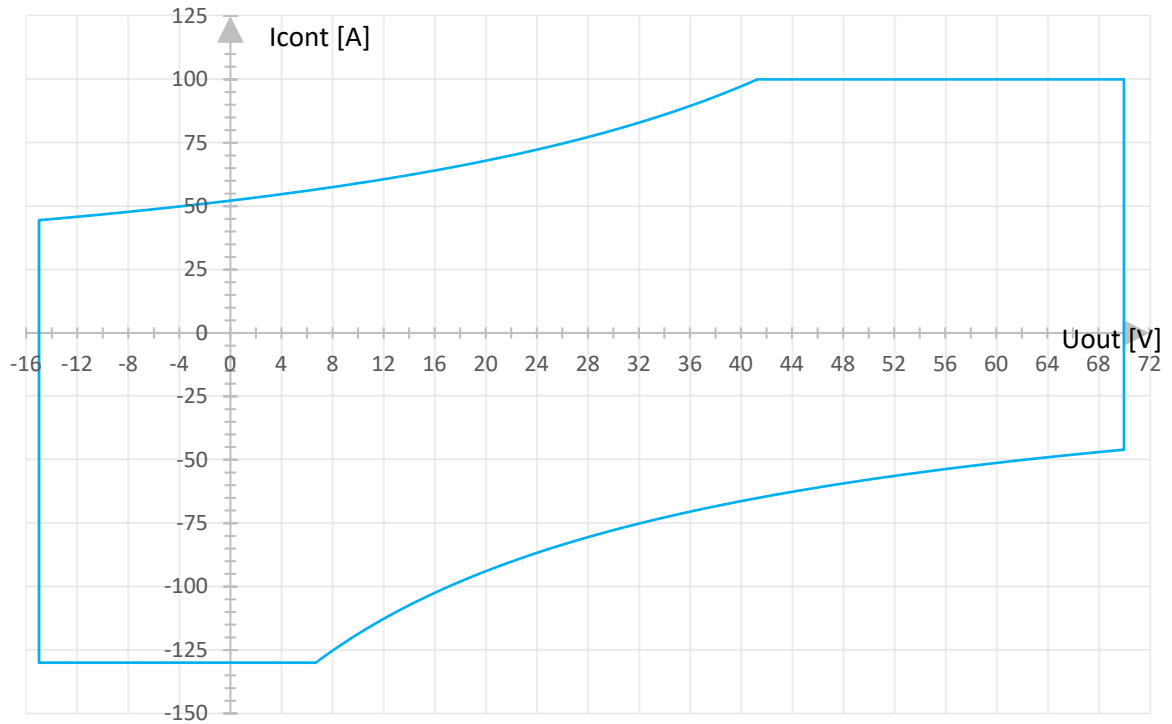

70V Range short-time current I_{short} : **LVA5000**

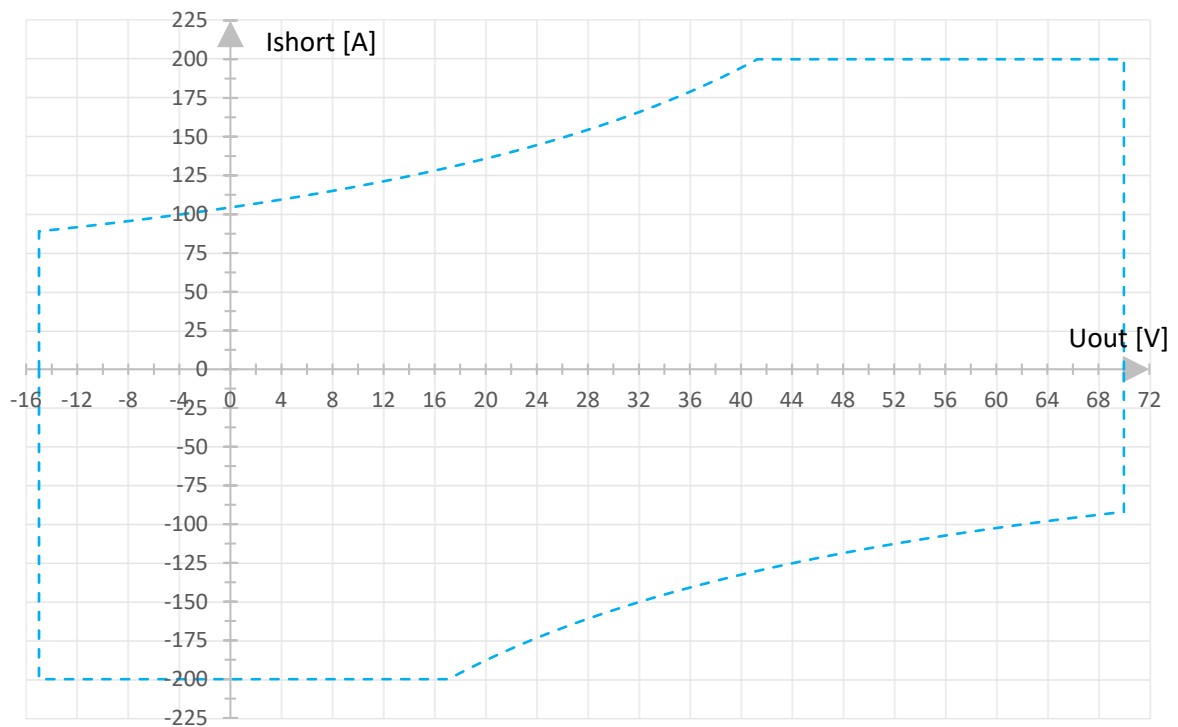

TECHNICAL DATA

Max. peak current capability (up to 200ms)		600A _p	
Continuous and short-time output current capability		range depending see diagrams	
Nominal voltage ranges		U ₁ : -15V _{DC} ... 20V _{DC} U ₂ : -15V _{DC} ... 36V _{DC} U ₃ : -15V _{DC} ... 54V _{DC} U ₄ : -15V _{DC} ... 70V _{DC}	
Digital instrument	Voltage range	Autoranging (20/40/80V _{DC} Ranges)	
	Current range	75A / 150A / 300A / 600A	
Accuracy Voltage		DC: 1000ppm of reading / 200ppm of range value	
Accuracy Current		DC: 2000ppm of reading / 400ppm of range value	
Supply	Power Supply	230V/400V (±10%, 50/60Hz)	
	Protection	32A	
	Connector type	CEE	
Housing		19"-rack, colour light grey (RAL 7035)	
Dimensions (mm)		24" rack: 1320x600x1050 37" rack: 1920x600x1050	
Weight		LVA integrated in 24" rack: approx. 400kg LVA integrated in 37" rack: approx. 440kg	
General	Voltage adjustment	Touch panel / Remote / External input	
	Load regulation 0 ... nominal load	max. 0.2%, typ. <0.1%	
	Internal resistance compensation	DC ... 1kHz (-3dB)	
	Frequency range (no load)	DC ... 100kHz large signal bandwidth (-3dB) DC ... 300kHz small signal bandwidth (10% of range, -3dB)	
	Noise at output	<5mV _{rms} (<100kHz), <10mV _{rms} (100kHz - 20MHz)	
	Slew rate	SR: >20V/μs	
	Adjustable current limitation	Accuracy see current measurement unit response time < 20μs	
	Floating output	Max. voltage between earth and amplifier output ground: 300V _{rms}	
	Internal control oscillator	Type	4-channel synthesizer
		Wave form	DC, Sine, Rectangle, Triangle, DC Offset, Arbitrary
Amplitude resolution		17Bit	
Frequency range		DC ... 1MHz	
Frequency resolution		1μHz	
Frequency accuracy		25ppm	
Memory depth		1MSample	
Synth functions		ADD, AM, FM, PM	
Sequence memory		1024 steps	
External floating input		V: 0 ... ±5V _{DC} (Input resistance: 11.5 kΩ)	
Digital I/O	8 digital inputs +5V _{DC} ... +24V _{DC} 8 digital outputs +5V _{DC} , I _L =40mA (external V _{CC} input: +5V _{DC} ... +24V _{DC} , I _L =500mA)		

Monitoring unit ²⁾	voltage	current
<i>Max. output</i>		±10V _p
<i>Scaling factor (adjustable)</i>	0.2 ... 1000	0.1 ... 1000
<i>Bandwidth</i>	300kHz	200kHz
<i>Accuracy</i>		0.3%
<i>Noise of ADC measurement</i>	<20mV _{rms} (DC ... 300kHz)	<1.5mA _{rms} (DC ... 300kHz)
<i>Noise DAC output</i>	<0.2mV _{rms} (DC ... 300kHz)	
<i>Delay time</i>	<1µs	
<i>Output impedance</i>	220Ohm	
<i>Isolation</i>	earth / remaining electronics / each other	
<i>Protection</i>	short circuit	
Insulation resistance	>1MOhm	
Withstand voltage	>2000V _{DC}	
Ambient temperature	0°C up to 40°C	
Relative Humidity (non-condensing)	max. 80% for temperatures <31°C, decreasing linearly to 50% at 40°C	
System of protection	IP20	

LVA 5000 AMPLIFIER – OPTIONS

OPT.01	IEEE 488 Interface
OPT.02	RS 232 Interface (instead of IEEE 488 Interface)
OPT.05	Output voltage and current monitor (electrically isolated) Probe ratio free adjustable
NT.11.70S.5K	Symmetrical voltage range (for magnetic field tests) V:0 ... ± 70V _{DC} / I _{DC,cont} :20 A _{DC} / I _{DC,short} :25 A _{DC}
OPT.24.04	Programmable internal resistance R:0mΩ ... 200.0mΩ / Accuracy: ±1% of range
OPT.25.04	Constant current mode
OPD.04	Overvoltage Protection Device

The LVA is also available as LVA 1000, LVA 2500 and LVA 7500 version.

LVA 4-Quadrant Amplifier 7500

**AUTOMOTIVE SUPPLY SIMULATION
AT IT'S BEST**



Example: LVA 1000 Front panel

- ✓ Extremely low harmonic distortion - even under very non-linear load conditions
- ✓ Very fast slew rate > 20V/μs
- ✓ Operates from DC up to 100kHz large signal bandwidth (-3dB)
- ✓ Small signal bandwidth up to 300kHz
- ✓ High short-term overload characteristic (for 30s)
- ✓ Very high peak-load ability (up to 200ms)
- ✓ Programmable internal resistance 0 ... 200mΩ
- ✓ Sink operation mode can be disabled
- ✓ Touch panel operation 7" 800x480
- ✓ Optional overvoltage protection device OPD

The relating standards:

ISO 7637-2/-3
 ISO 16750-2
 ISO 21848
 LV 124
 VDA 320 (LV 148)
 SAE J 1113-11
 BMW GS 95002
 BMW GS 95003-2
 BMW GS 95024-2-2
 BMW GS 95026
 Ford FMC 1278
 General Motors GMW 3097
 JLR-EMC-CSv1.4
 Mercedes-Benz MBN
 LV124-1
 PSA B21 7110
 Renault 36-00-808/--M
 VW TL 81000
 VW 80000
 VW 82148

THE REFERENCE SOURCE FOR AUTOMOTIVE APPLICATIONS

AMPLIFIER CHARACTERISTIC – OUTPUT CURRENT CAPABILITY

20V Range continuous current I_{cont} : LVA7500

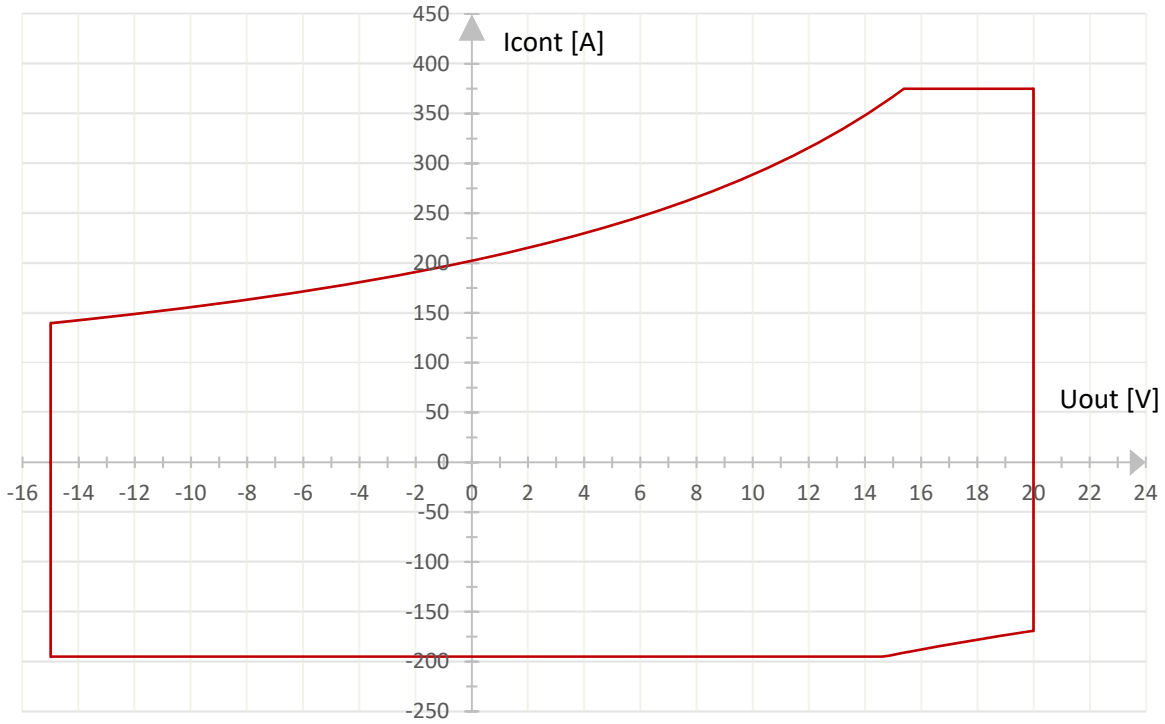

20V Range short-time current I_{short} : LVA7500

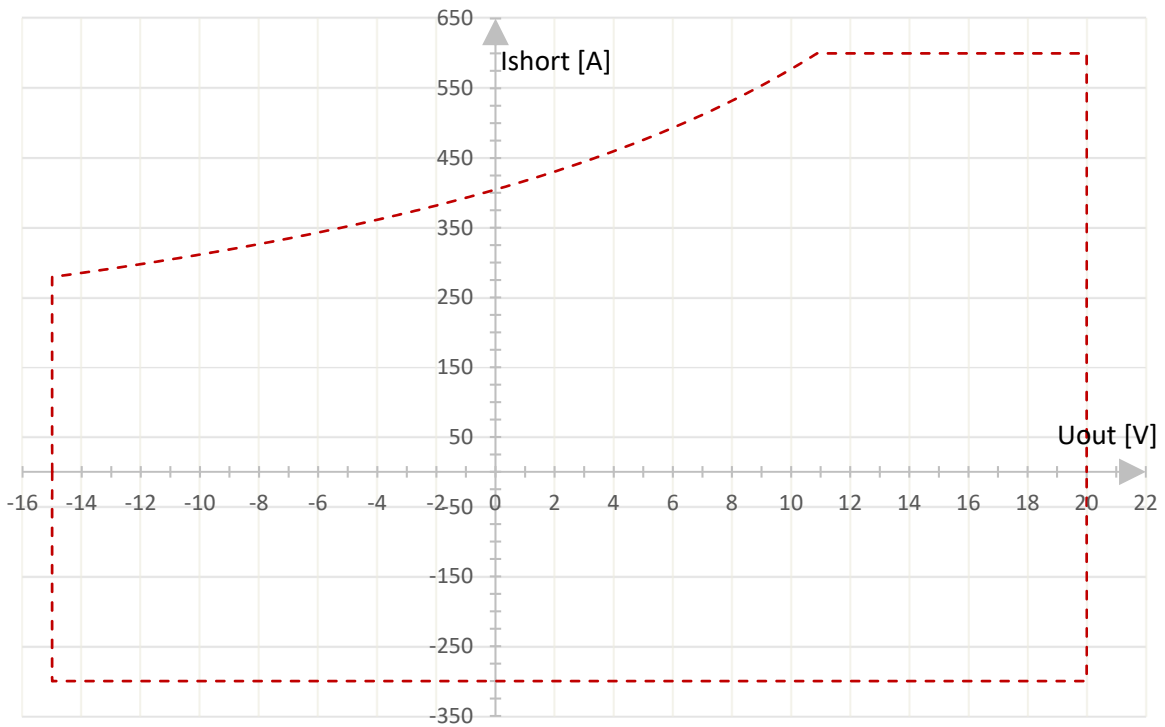

AMPLIFIER CHARACTERISTIC – OUTPUT CURRENT CAPABILITY

36V Range continuous current I_{cont} : LVA7500

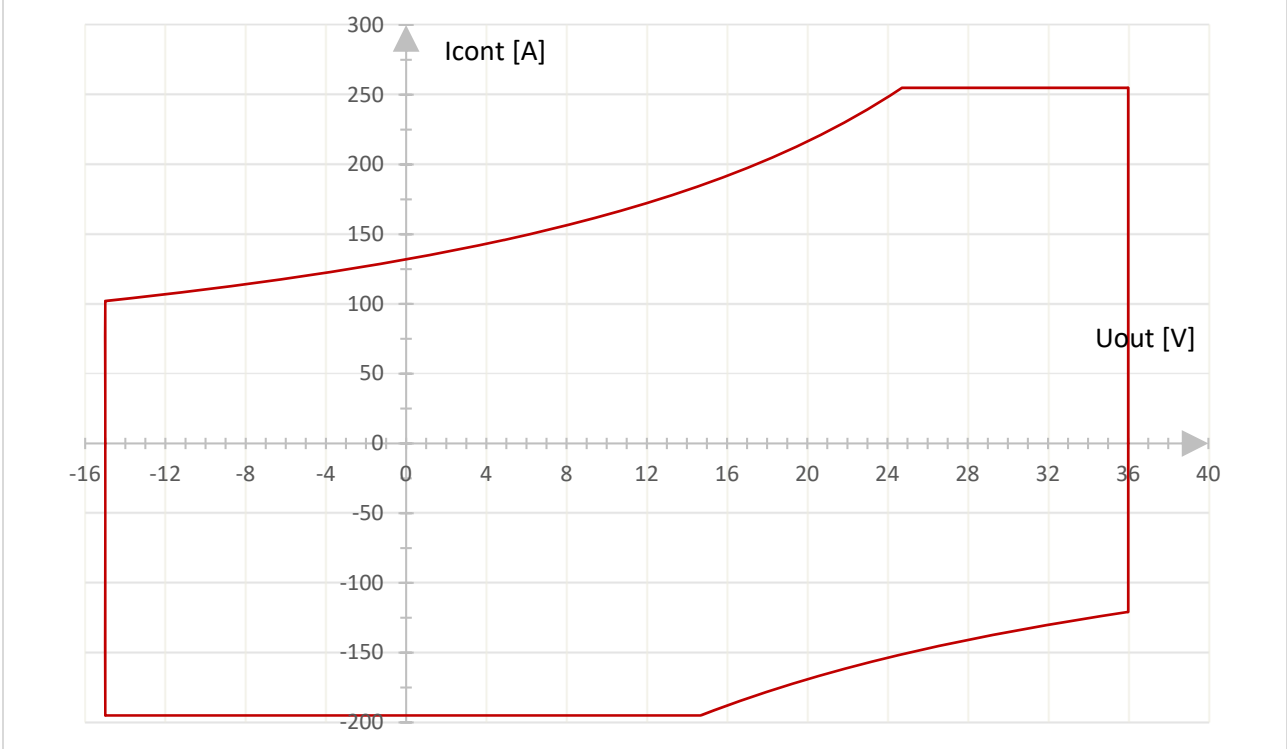

36V Range short-time current I_{short} : LVA7500

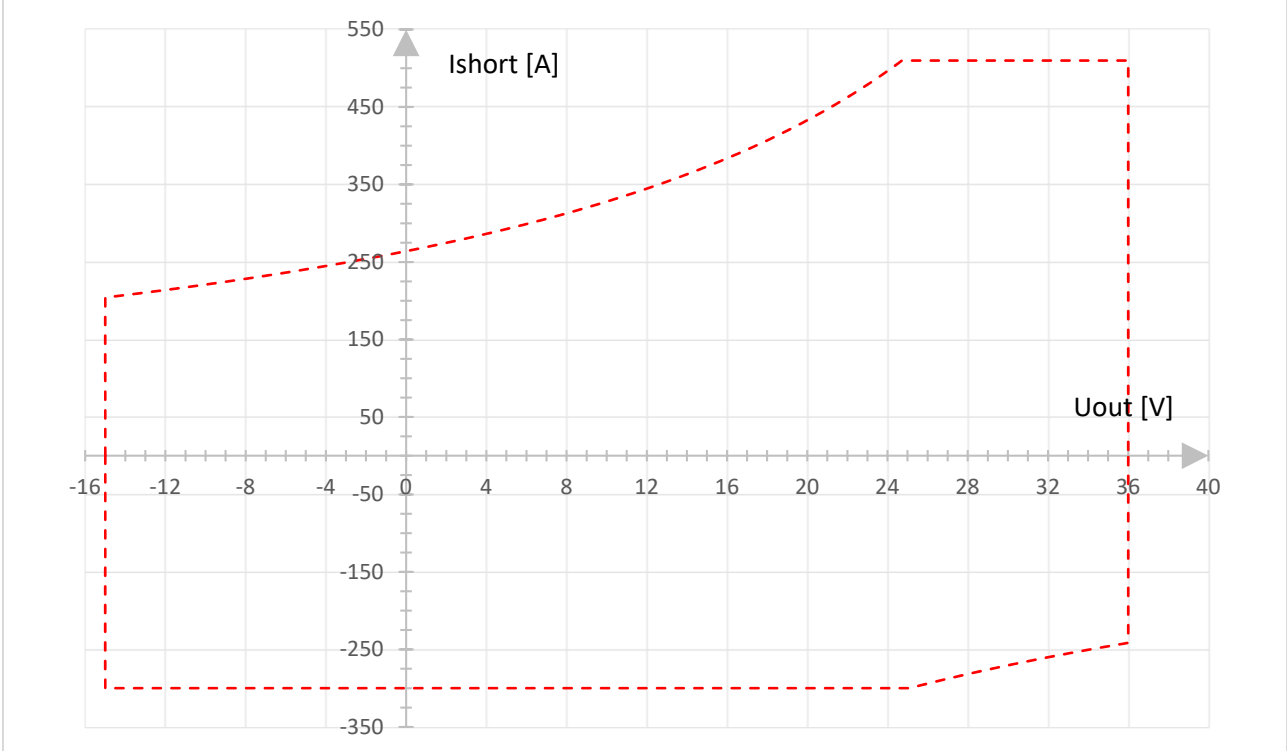

AMPLIFIER CHARACTERISTIC – OUTPUT CURRENT CAPABILITY

54V Range continuous current I_{cont} : **LVA7500**

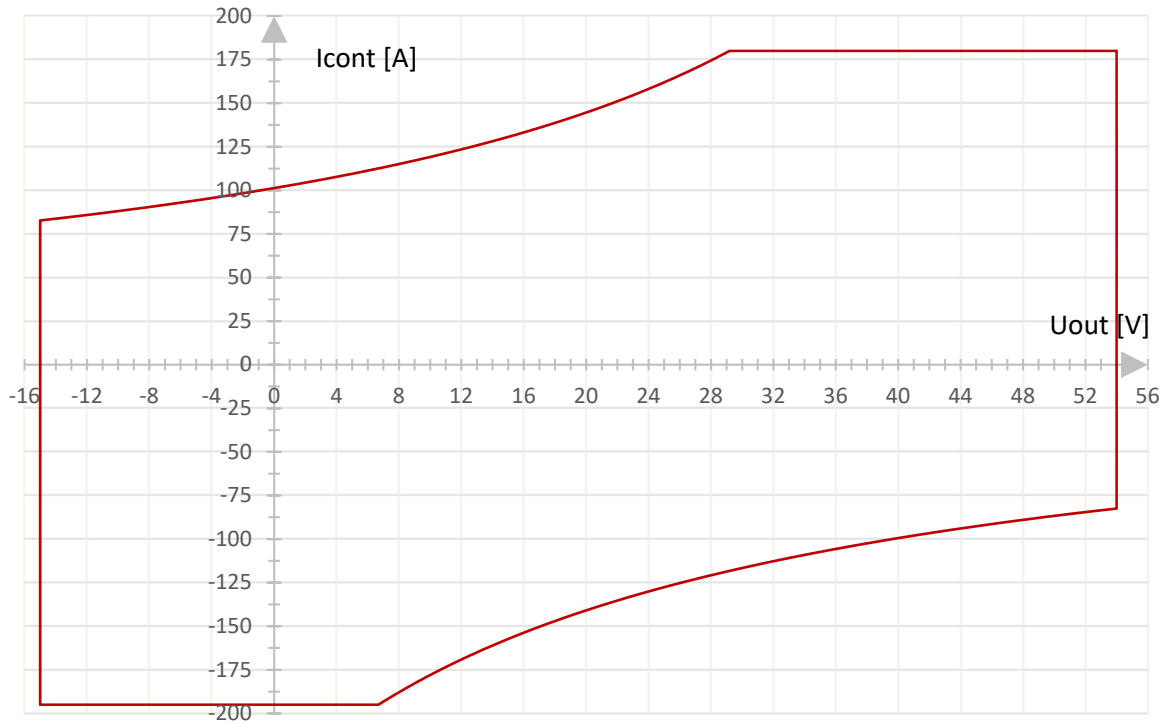

54V Range short-time current I_{short} : **LVA7500**

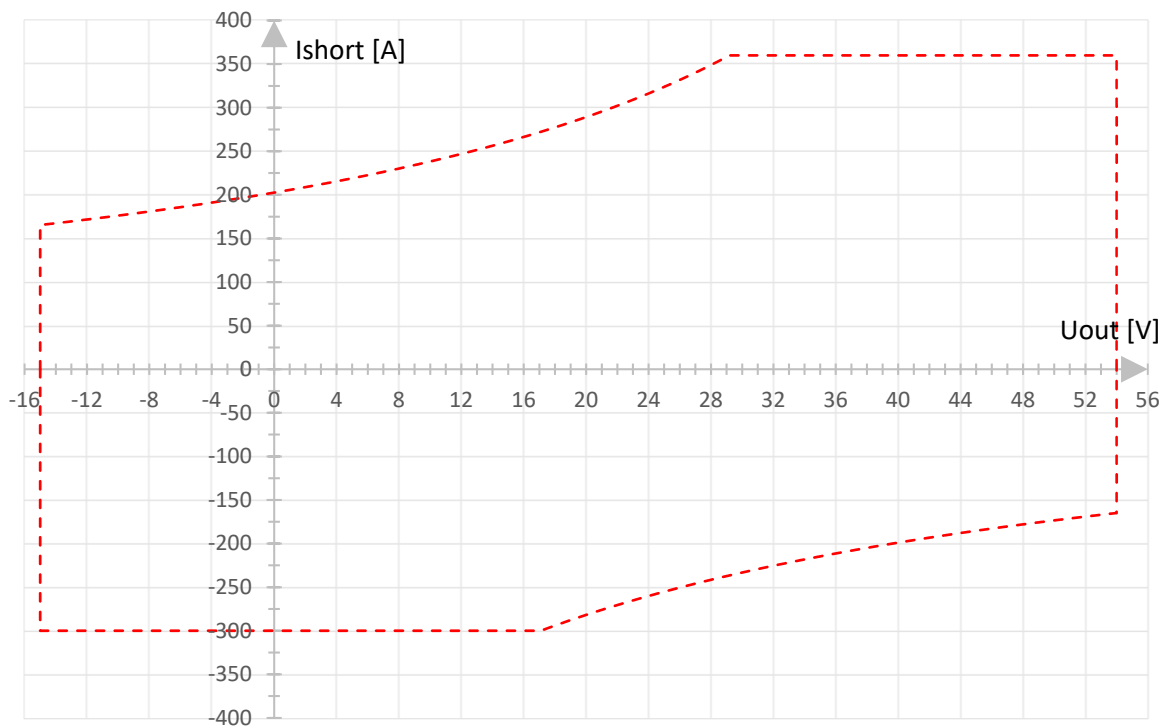

AMPLIFIER CHARACTERISTIC – OUTPUT CURRENT CAPABILITY

70V Range continuous current I_{cont} : **LVA7500**

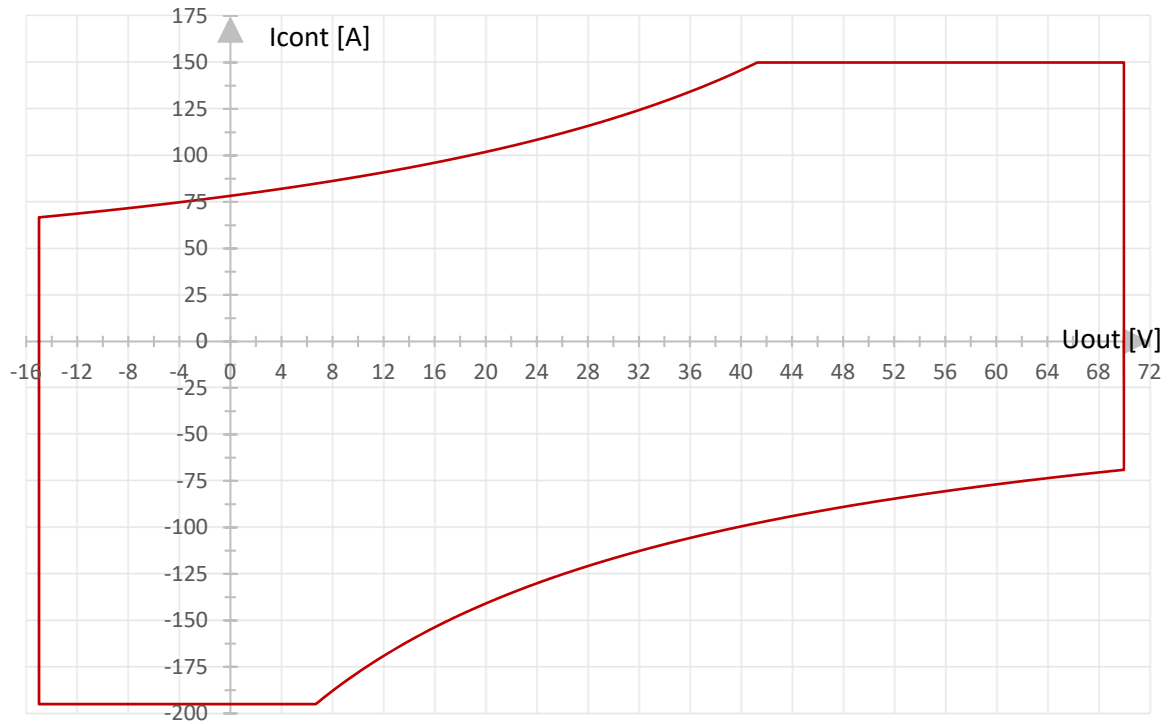

70V Range short-time current I_{short} : **LVA7500**

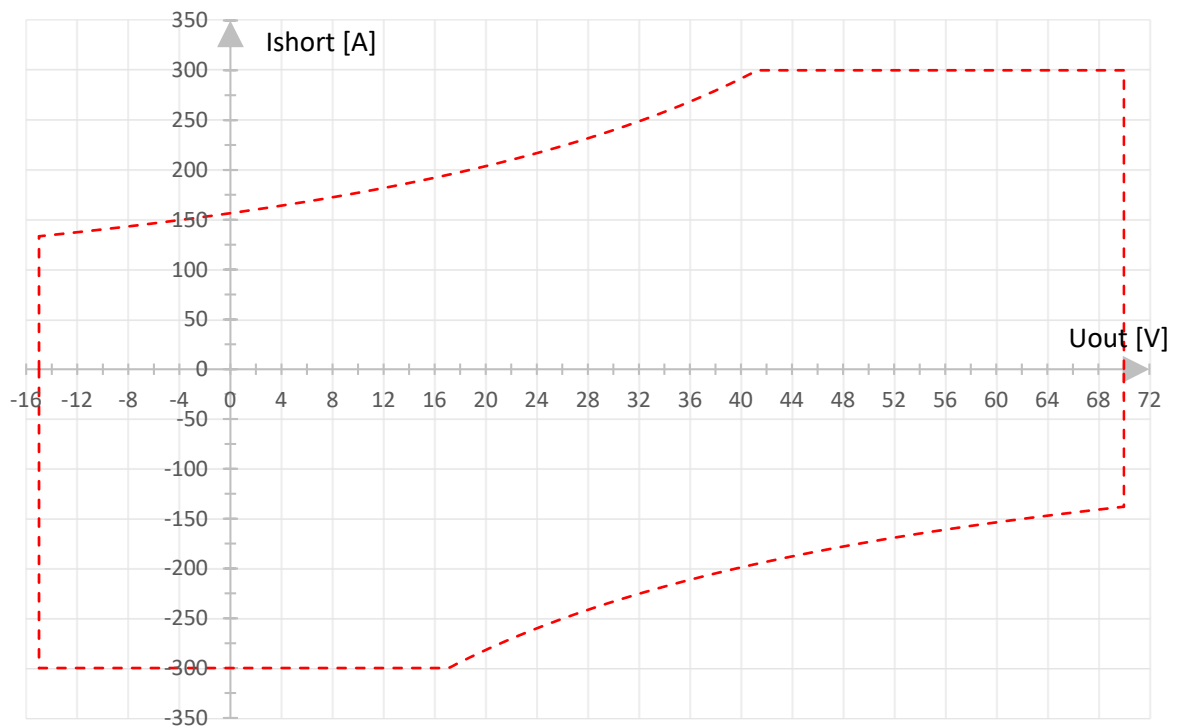

TECHNICAL DATA

Max. peak current capability (up to 200ms)		900A _p
Continuous and short-time output current capability		range depending see diagrams
Nominal voltage ranges		U ₁ : -15V _{DC} ... 20V _{DC} U ₂ : -15V _{DC} ... 36V _{DC} U ₃ : -15V _{DC} ... 54V _{DC} U ₄ : -15V _{DC} ... 70V _{DC}
Digital instrument	Voltage range	Autoranging (20/40/80V _{DC} Ranges)
	Current range	125A _{DC} / 250A _{DC} / 500A _{DC} / 1000A _{DC}
Accuracy Voltage		DC: 1000ppm of reading / 200ppm of range value
Accuracy Current		DC: 2000ppm of reading / 400ppm of range value
Supply	Power Supply	230V/400V (±10%, 50/60Hz)
Protection		32A
Connector type		CEE
Housing		19"-rack, colour light grey (RAL 7035)
Dimensions (mm)		24" rack: 1320x600x1050 37" rack: 1920x600x1050
Weight		LVA integrated in 24" rack: approx. 460kg LVA integrated in 37" rack: approx. 500kg
General	Voltage adjustment	Touch panel / Remote / External input
Load regulation: 0 ... nominal load		max. 0.2%, typ. <0.1%
Internal resistance compensation		DC ... 1kHz (-3dB)
Frequency range (no load)		DC ... 100kHz large signal bandwidth (-3dB) DC ... 300kHz small signal bandwidth (10% of range, -3dB)
Noise at output		<5mV _{rms} (<100kHz), <10mV _{rms} (100kHz - 20MHz)
Slew rate		SR: >20V/μs
Adjustable current limitation		Accuracy see current measurement unit response time < 20μs
Floating output		Max. voltage between earth and amplifier output ground: 300V _{rms}
Internal control oscillator	Type	4-channel synthesizer
Wave form		DC, Sine, Rectangle, Triangle, DC Offset, Arbitrary
Amplitude resolution		17Bit
Frequency range		DC ... 1MHz
Frequency resolution		1μHz
Frequency accuracy		25ppm
Memory depth		1MSample
Synth functions		ADD, AM, FM, PM
Sequence memory		1024 steps
External floating input		V: 0 ... ±5V _{DC} (Input resistance: 11.5 kΩ)
Digital I/O		8 digital inputs +5V _{DC} ... +24V _{DC} 8 digital outputs +5V _{DC} , I _L =40mA (external V _{CC} input: +5V _{DC} ... +24V _{DC} , I _L =500mA)

Monitoring unit ²⁾	voltage	current
<i>Max. output</i>		±10V _p
<i>Scaling factor (adjustable)</i>	0.2 ... 1000	0.1 ... 1000
<i>Bandwidth</i>	300kHz	200kHz
<i>Accuracy</i>		0.3%
<i>Noise of ADC measurement</i>	<20mV _{rms} (DC ... 300kHz)	<1.5mA _{rms} (DC ... 300kHz)
<i>Noise DAC output</i>	<0.2mV _{rms} (DC ... 300kHz)	
<i>Delay time</i>	<1µs	
<i>Output impedance</i>	220Ohm	
<i>Isolation</i>	earth / remaining electronics / each other	
<i>Protection</i>	short circuit	
Insulation resistance	>1MOhm	
Withstand voltage	>2000V _{DC}	
Ambient temperature	0°C up to 40°C	
Relative Humidity (non-condensing)	max. 80% for temperatures <31°C, decreasing linearly to 50% at 40°C	
System of protection	IP20	

LVA 7500 AMPLIFIER – OPTIONS

OPT.01	IEEE 488 Interface
OPT.02	RS 232 Interface (instead of IEEE 488 Interface)
OPT.05	Output voltage and current monitor (electrically isolated) Probe ratio free adjustable
NT.11.70S.	Symmetrical voltage range (for magnetic field tests) V:0 ... ± 70V _{DC} / I _{DC,cont} :20 A _{DC} / I _{DC,short} :25 A _{DC}
OPT.24.P.	Programmable internal resistance R:0mΩ ... 200.0mΩ / Accuracy: ±1% of range
OPT.25.	Constant current mode
OPD.	Overvoltage Protection Device

The LVA is also available as LVA 1000, LVA 2500 and LVA 5000 version.

2/4-Quadrant-Amplifier-Set type LPA 50/GN/3

The relating standards:
Ford FMC 1278
JLR-EMC-CSv1.2

The 2/4-Quadrant-Amplifier-Set LPA 50/GN/3 can be used for the generation of pulses according to Ford standard Ford FMC 1278 and Jaguar standard JLR-EMC-CSv1.2

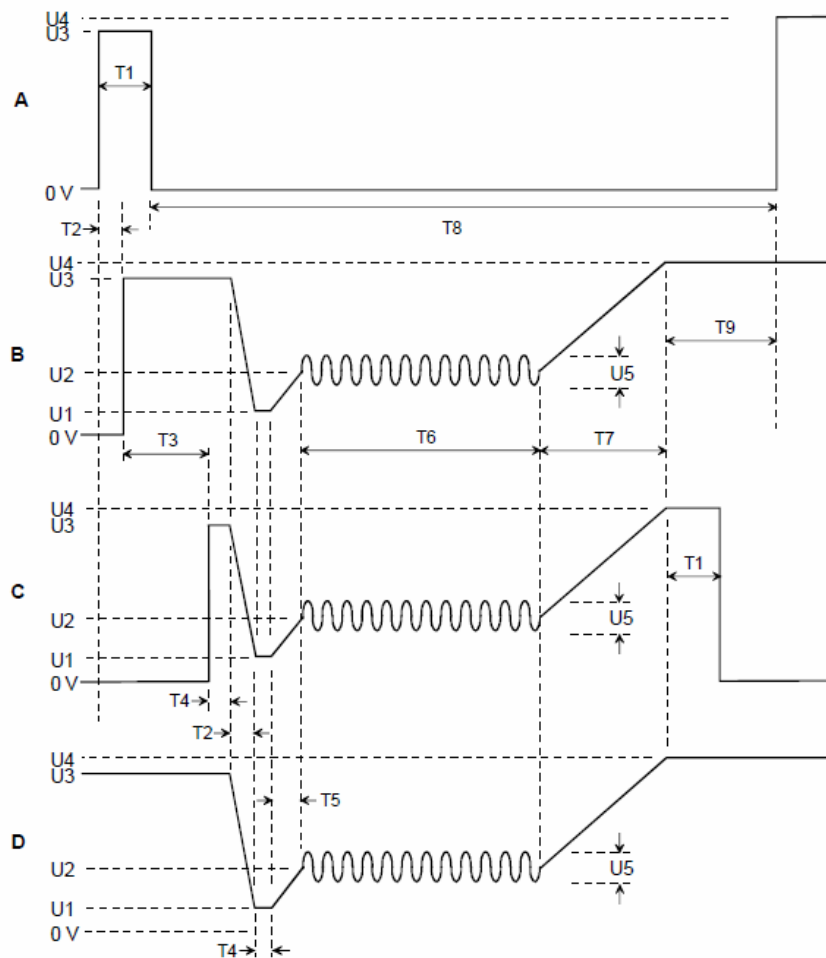

„Pulse CI230“

TECHNICAL DATA

Applications:	Immunity against Transient Disturbances
Continuous power:	50W (at nominal voltage)
Nominal voltage:	U ₁ : 0 ... 18V _{DC} / I _{cont} :4A _{DC} U ₂ : 0 ... 36V _{DC} / I _{cont} :2A _{DC} U ₃ : 0 ... 60V _{DC} / I _{cont} :1A _{DC} U _{1..3} : 0 ... -5V _{DC} / I _{cont} :0.5A _{DC}
Voltage adjustment:	depending on oscillator used
Load regulation:	< 1.5% (0...nominal load)
Gain stability:	10min: < 0.2% at constant load and temperature 8h: < 0.5% at constant load and temperature
Frequency range:	DC ... 300kHz small signal bandwidth
Rise time:	U ₁ : >1V/μs U ₂ : >2V/μs U ₃ : >3V/μs
Protection circuits:	overload / short circuit / overtemperature
Input:	
Input voltage: (for max. output voltage)	+5V _p
Input impedance:	approx. 10kΩ
Interface:	IEEE488
Power supply:	230V (±10%) 50Hz ... 60Hz
Protection:	2A
Ambient temperature:	0°C ... +40°C
Housing:	Sub-drawer system in 19"-plug-in unit (3U) colour light grey (RAL 7035)
<i>Dimensions (mm):</i>	approx. 135x483x450
<i>Weight:</i>	approx. 15kg

Test Pulse Generator type TDG/Ford

The relating standards:

Ford FMC 1278

Ford CI 220

Ford CI 260

The Test Pulse Generator TDG/Ford can be used for testing the immunity against Transient Disturbances CI 220 / CI 260.



TECHNICAL DATA

Applications:	Immunity from Transient Disturbances CI 220 / A1, A2, B1, B2 Immunity to Voltage Dropout CI 260 (Random Bounce)
Input voltage:	12 ... 14V _{DC}
Output:	Puls CI 220 A1, A2, C Puls CI 220 B1, B2 Puls CI 260 F
Hour meter:	Count-up (100h) with reset function
Interface:	IEEE488
Power supply:	230V (±10%) 50Hz ... 60Hz
Protection:	2A
Ambient temperature:	0°C ... +40°C
Housing:	Sub-drawer system in 19"-plug-in unit (3U) colour light grey (RAL 7035)
<i>Dimensions (mm):</i>	approx. 135x483x450
<i>Weight:</i>	approx. 15kg

High voltage tester HA 1800M

*The relating standards:
 ISO 16750-2
 ISO 21848.5
 many worldwide HV and isolation
 testing standards*

The high voltage tester HA1800M can be used for high voltage tests withstand and insulation resistance tests according to ISO 16750-2 and many worldwide test standards. It has an integrated safety current limitation at AC and DC mode testing.



TECHNICAL DATA

Applications:	Withstand voltage test according to ISO 16750-2 (4.11) or ISO/CD 21848.5 (4.10) Insulation resistance test according to ISO 16750-2 (4.12) or ISO/CD 21848.5 (4.10)
High voltage test AC:	
<i>voltage range:</i>	100 ... 5500V
<i>current range:</i>	0 ... 3mA
<i>short circuit current:</i>	<3mA
High voltage test DC:	
<i>voltage range:</i>	100 ... 6000V
<i>current range:</i>	0 ... 10mA
<i>short circuit current:</i>	<12mA
<i>ripple:</i>	<3% acc. to VDE 0432
Isolation test DC:	
<i>voltage range:</i>	100 ... 6000V
<i>measuring range (voltage dependent):</i>	250kOhm ... 10GOhm
<i>ripple:</i>	<3% acc. to VDE 0432
Generic information:	
<i>limit values:</i>	programmable
<i>error messages:</i>	optic and acoustic
<i>ramp function:</i>	programmable (IEC601)
Interfaces:	
<i>PC:</i>	Ethernet/LAN, 2xUSB, RS232
<i>24V_{DC} digital interface:</i>	8 input + 8 output
Power supply:	230V (±10%) 50Hz ... 60Hz
Ambient temperature:	0°C ... +40°C
Housing:	desktop housing
<i>Dimensions:</i>	approx. H=159mm; W=360mm; D=331mm
<i>Weight:</i>	approx. 10kg

"Spitzenberger & Spies offers extra protection for expensive prototype cars"

High currents require extra protection devices. Thinking about luxury and upper-class automobiles, currents up to 800A for the initial motor startup are necessary. Everybody can imagine, in which dimensions a simulation system for automotive supply networks has to be.

Taking a fully equipped modern limousine as an example, many different power consuming units are on board. Motoric devices as well as high speed heating systems for front windows and lots of other appliances. All of them require immediately high currents for their desired operation.

*The relating standards:
ISO 7637
ISO 16750-2
ISO 21848
BMW GS 95002
and many manufacturers test specifications*



At the prototyping cycle of current cars in in-house testing facilities (according to ISO 7637 and lots of manufacturer specific test regulations) a programmable DC power supply source with a very high current capability, very short rise time (+/-), very low internal resistance and a very high peak power capability is absolutely necessary.

A well-known representative of such a voltage source is the PAS 15000 GN/Kfz, able to deliver short time currents far above 1000A. With such a simulator devices with high-energy needs can be tested also.

During any test run the protection of the (mostly expensive) prototype against overvoltage must be most important.

In any case of fault condition the supply source must be prevented from delivering power into the prototype system. If not, uncontrollable damages of the system up to burning fire can happen. Spitzenberger & Spies has developed an **overvoltage protection device OPD** suitable for the above mentioned purpose. It is offered as an optional unit for the well-proved Spitzenberger automotive supply simulator series PAS xxx GN/Kfz.



The functional principle of the OPD is a mechanical power switch with a monitoring and supervising unit. This switching unit is located between the simulator and the EUT.

To afford maximum security **the monitoring of the output voltage is set up as a redundant system**. On the one hand the output voltage is supervised directly at the EUT through external sense lines. On the other hand the current flow through the protection diodes of the supervising unit is analyzed. The OPD output is enabled only if both monitoring units evaluate "ok".

Additionally the polarity of the output voltage is supervised.

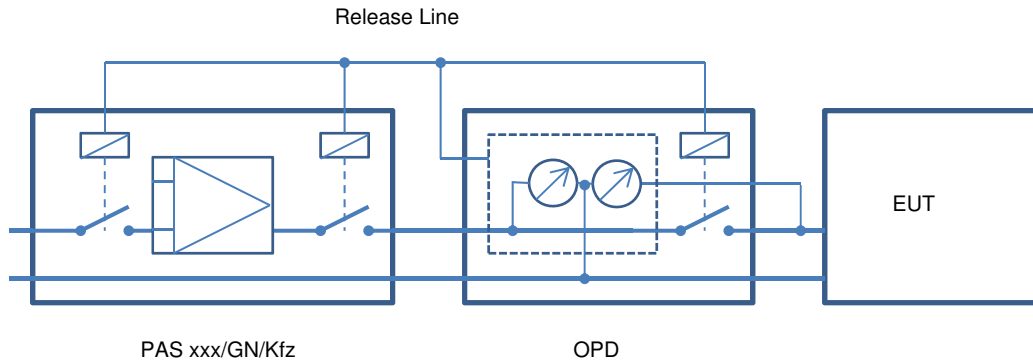

The release line controls the cut-off switches inside the OPD and in the voltage input of the simulator

The main function of the electronic protection is to prevent the EUT from any damage until the mechanical switches have cut off the voltage. This duration is typically 20-30ms. The components inside this electronic protection must have an improved quality to withstand the voltage and power delivered to the EUT until the mechanical switches have released.

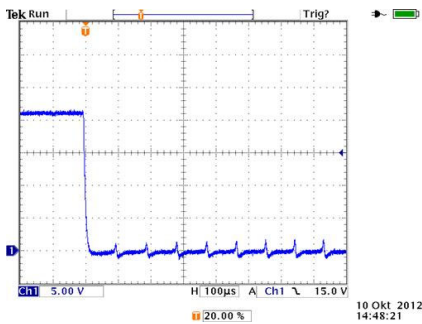

Release characteristic of the electronic protection (100µs/DIV)

Only one measured difference from the reference values is necessary to activate the protection sequence. In any case of fault the electronic monitoring unit activates immediately a multi-stage protection sequence.

Within µs an electronic protection cuts off the voltage to shield the EUT until the mechanical protection switch has released (typically 20-30 ms duration). The supply lines between EUT, OPD and the automotive supply simulator are disconnected, the whole system is de-energized.

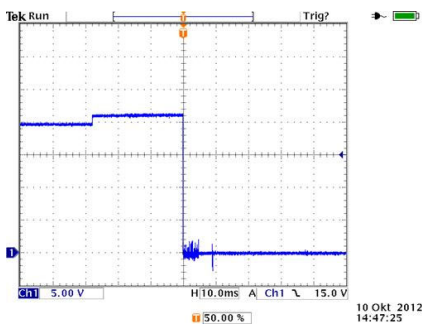

Release characteristic of the mechanical switch (10ms/DIV)

To guarantee a perfect protection the functionality of the protection unit is tested automatically at each startup (Power-On Self-Test). A manual function test can be performed at each time using the according front panel buttons.

As a reminder for the operator the output of the simulator is locked until the function test of the OPD is stating "OK". Only a passed function test is releasing the output of the simulator and the OPD.

The diagrams above show the typical switch-off duration of the OPD's electronic protection on the one hand and the release duration of the mechanical switches on the other hand.

The result is: The **Overvoltage Protection Device** is **the perfect bodyguard for expensive EUT's**.

Practical measurements Rise- and Fall-Time with the LVA 2500

The relating standards:
ISO 7637
VDA 320

Inside many international standards the risetime of a voltage source is one important criteria for the quality of the source.

The VDA 320, a standard coming from the original OEM standard LV 148 defines in several test setups a maximum rise- and falltime of 10µs.

OSCILLOSCOPE SCREENSHOTS

Figure 1:
Voltage dip
48V DC supply voltage and
dip to 0V for 10µs
10 Ω load

Measurement of
Risetime t_r
Falltime t_f

In both cases is the
measured transition time
below 1µs

Oscilloscope
R&S RTM
10V/DIV
TB 5µs/DIV

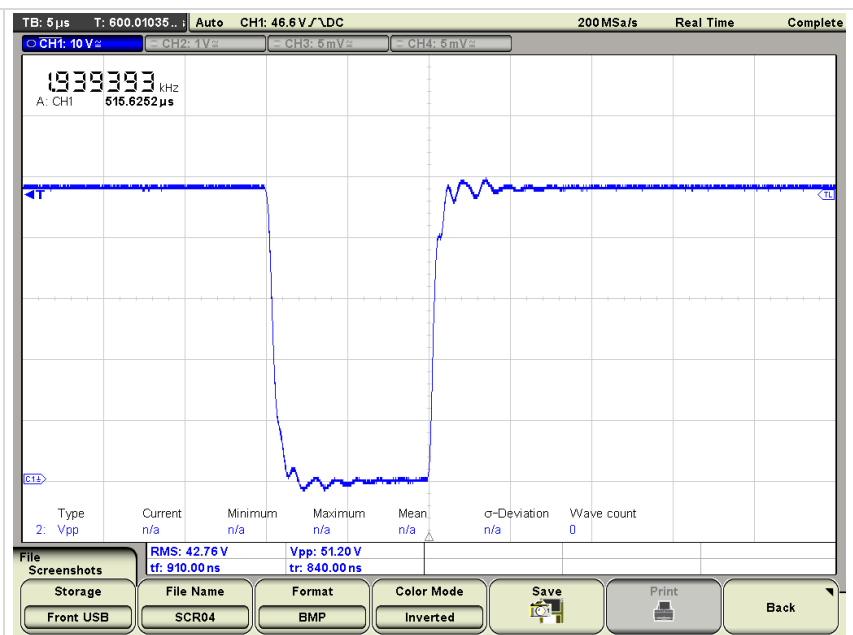

OSCILLOSCOPE SCREENSHOTS

Figure 2:
 Voltage rise
 Rise from 0V to 48V DC
 supply voltage
 10 Ω load

Measurement of
 Risetime t_r

The measured transition time
 is below 1 μ s.

Oscilloscope
 R&S RTM
 10V/DIV
 TB 0.5 μ s/DIV

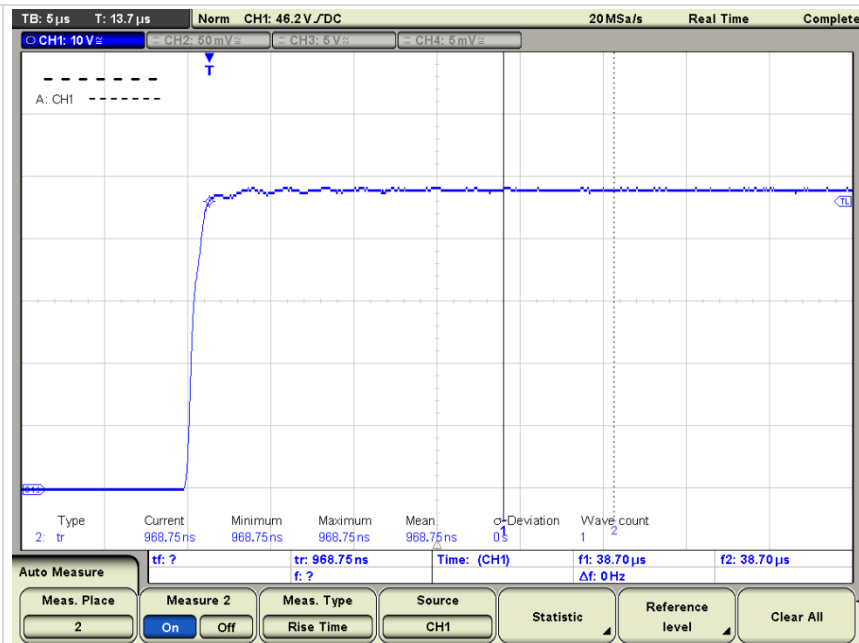
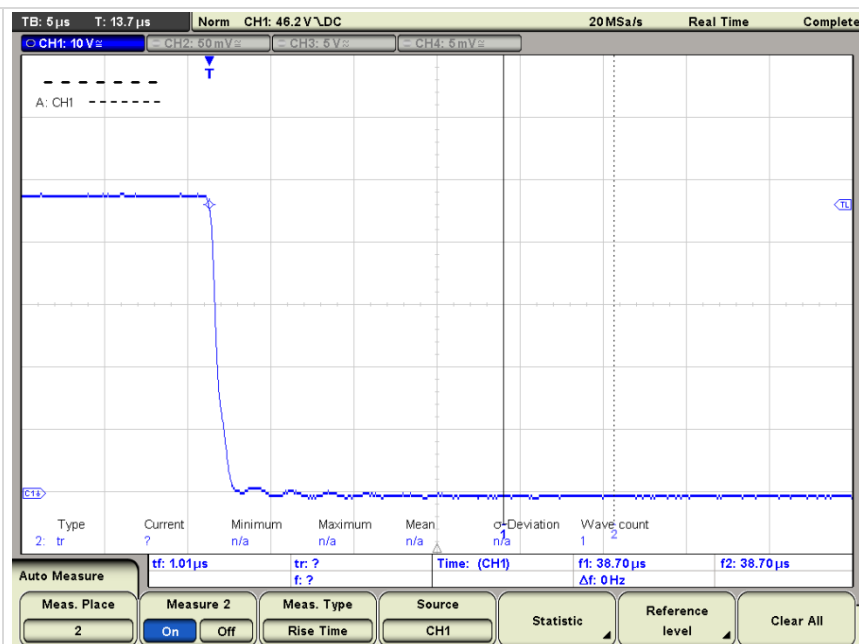

Figure 3:
 Voltage fall
 Fall from 48V DC supply
 voltage to 0V
 10 Ω load

Measurement of
 Falltime t_f

The measured transition time
 is below 1 μ s.

Oscilloscope
 R&S RTM
 10V/DIV
 TB 0.5 μ s/DIV



„Automotive source quality“

Spitzenberger & Spies – automotive supply simulation with optimum performance

Rise- and fall-time are one of the main quality points when looking at the performance of supply simulation systems. Comparing different technical solution ways a big quality difference is carried out.

The following measurements compare the performance of simple solutions with the performance of the Spitzenberger & Spies power sources. The upcoming result is, that minor proper solutions have an extremely reduced rise- and fall-time speed in comparison to the Spitzenberger & Spies system – **500 times slower**.

Looking at the measurement values, the PAS/GN/Kfz has a rise-/fall-time around 5-10 μs , the minor solution is around 2.6-3.3 ms

*The relating standards:
ISO 7637
ISO 16750-2
ISO 21848
BMW GS 95002
and many manufacturer
specific standards*

Comparison measurement 1:

Abrupt voltage change from 0V to 18V with a 10 Ω load connected

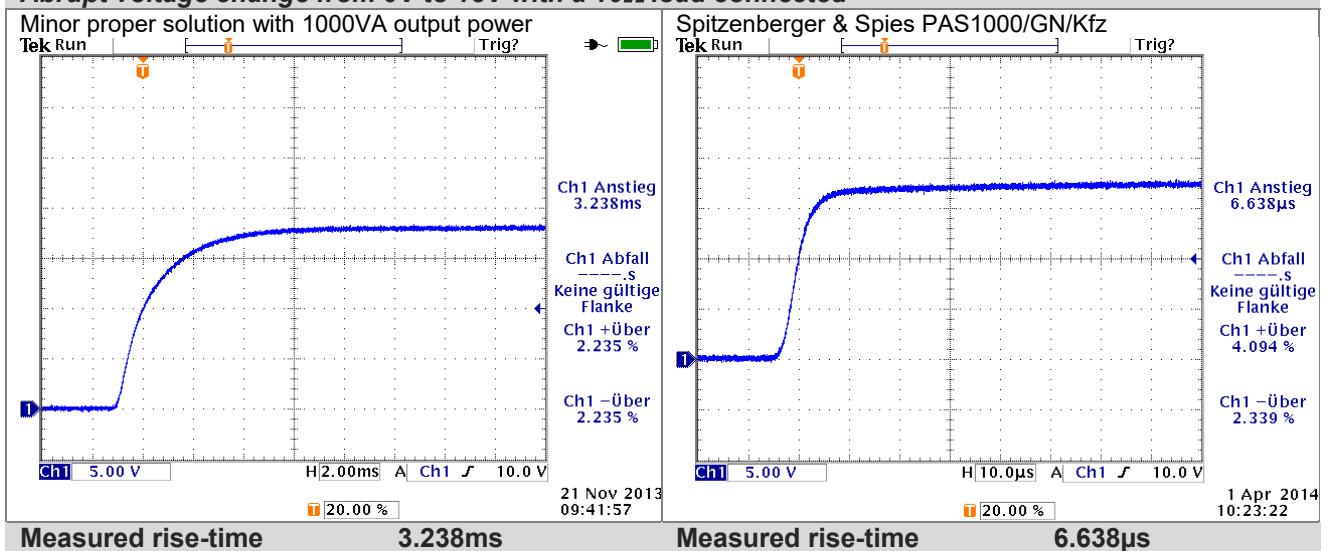

Comparison measurement 2:
Abrupt voltage change from 18V to 0V with a 10Ω load connected

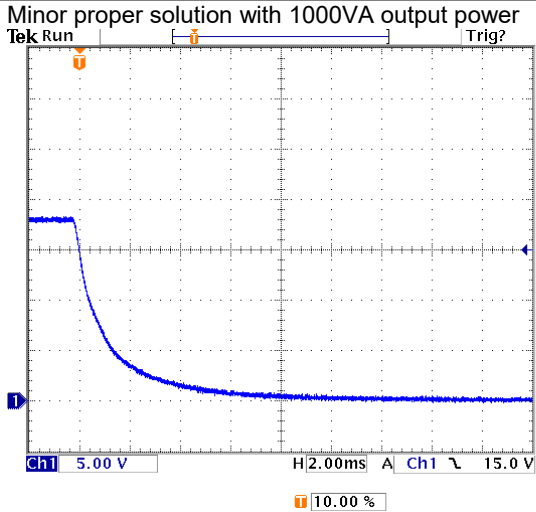

Measured fall-time 3.324ms

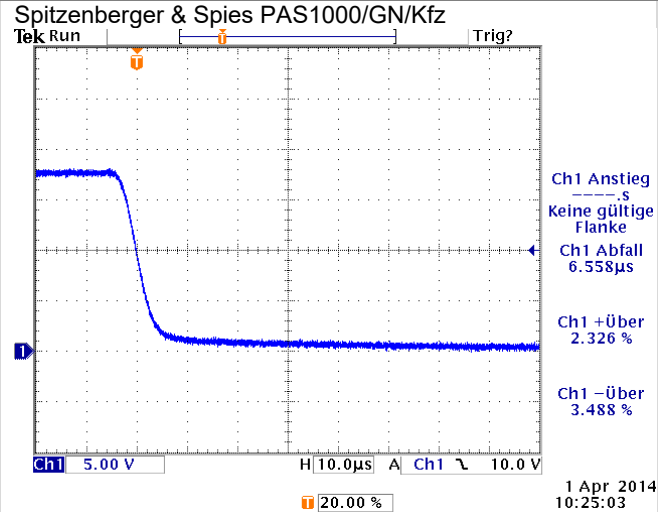

Measured fall-time 6.558μs

Comparison measurement 3:
Abrupt voltage change from 0V to 18V and back to 0V with a 10Ω load connected at a time resolution of 20ms/DIV

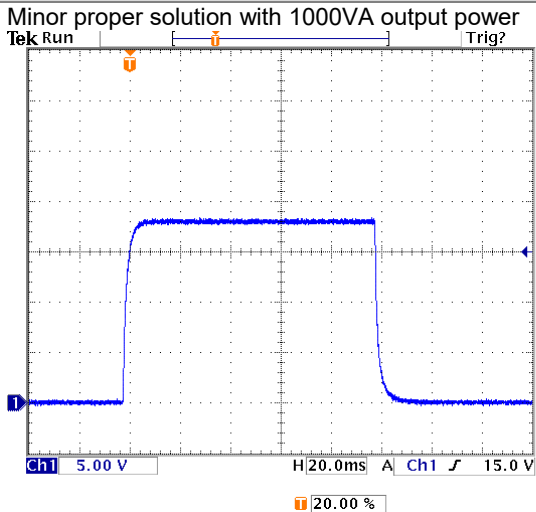

Measured rise-time 3.323ms
 Measured fall-time 3.378ms

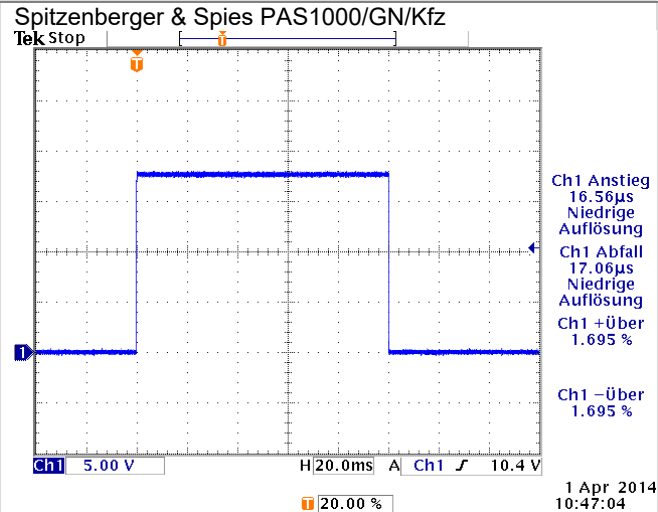

Measured rise-time 16.56μs
 Measured fall-time 17.06μs

Comparison measurement 4:
Abrupt voltage change from 0V to 36V with a 10Ω load connected

Minor proper solution with 1000VA output power

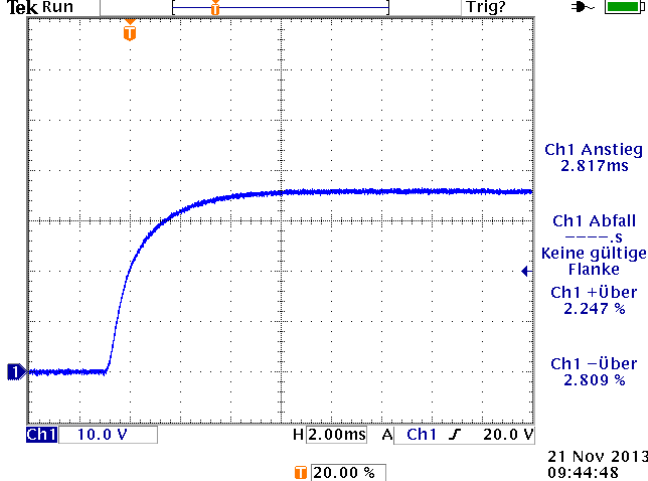

Measured rise-time 2.817ms

Spitzenberger & Spies PAS1000/GN/Kfz

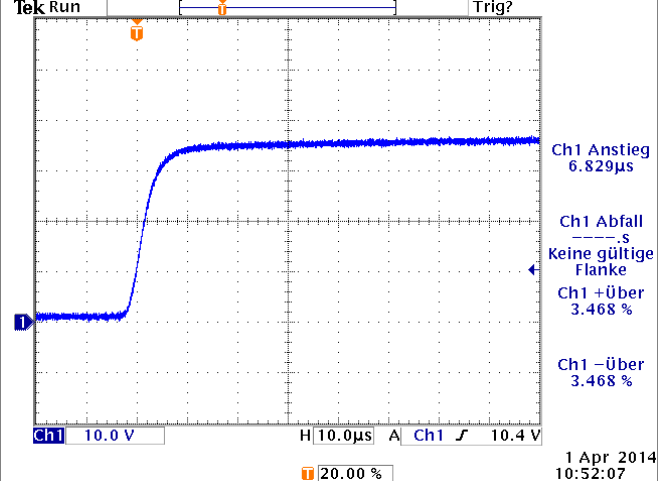

Measured rise-time 6.829µs

Comparison measurement 5:
Abrupt voltage change from 36V to 0V with a 10Ω load connected

Minor proper solution with 1000VA output power

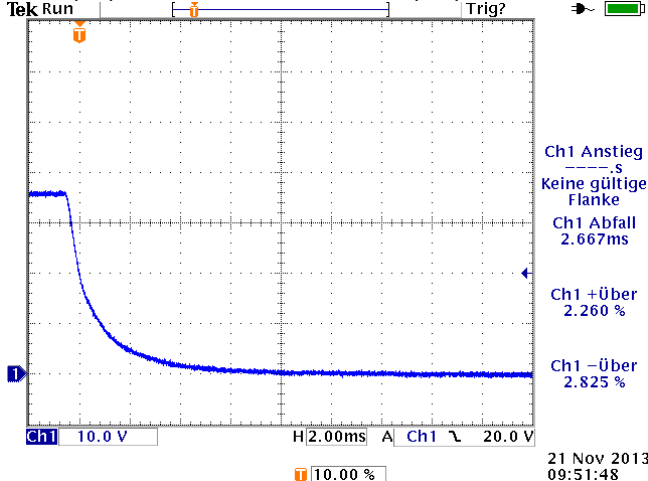

Measured fall-time 2.667ms

Spitzenberger & Spies PAS1000/GN/Kfz

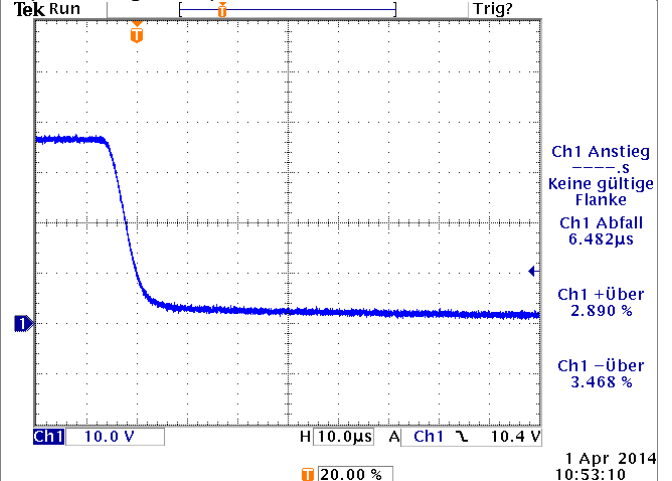

Measured fall-time 6.482µs

Comparison measurement 6:

Abrupt voltage change from 0V to 36V and back to 0V with a 10Ω load connected at a time resolution of 20ms/DIV

Minor proper solution with 1000VA output power

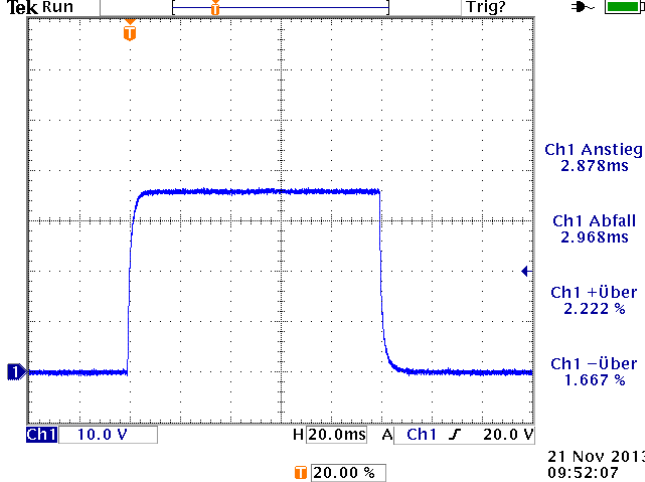

Spitzenberger & Spies PAS1000/GN/Kfz

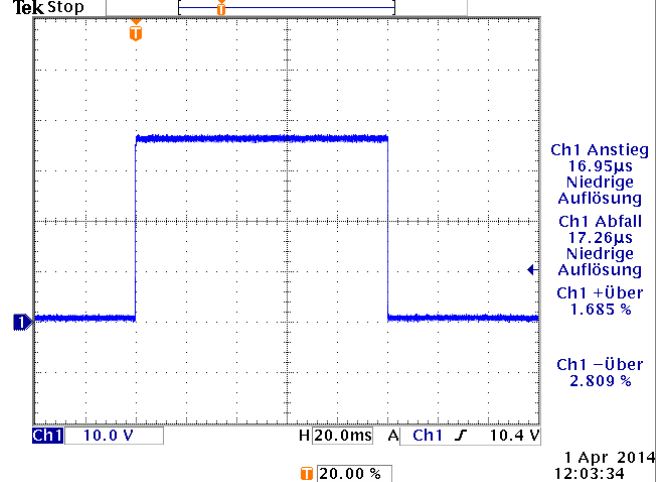

Measured rise-time 2.878ms
Measured fall-time 2.968ms

Measured rise-time 16.95µs
Measured fall-time 17.26µs

Comparison measurement 7:

Abrupt voltage change from 0V to 59.3V/60V with a 10Ω load connected (the minor proper solutions has a maximum voltage of 59.3V)

Minor proper solution with 1000VA output power

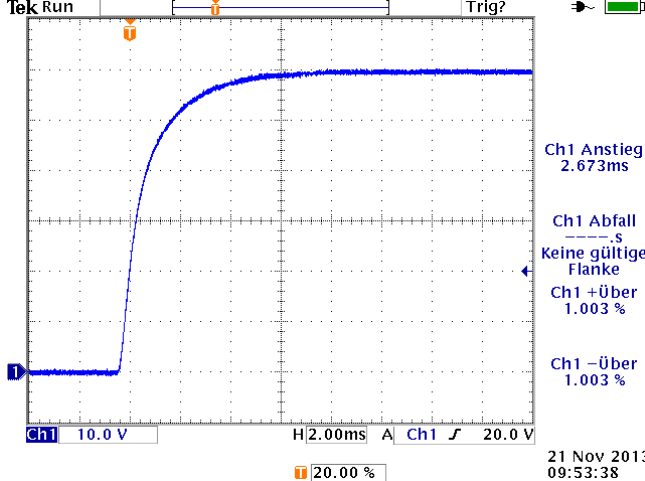

Spitzenberger & Spies PAS1000/GN/Kfz

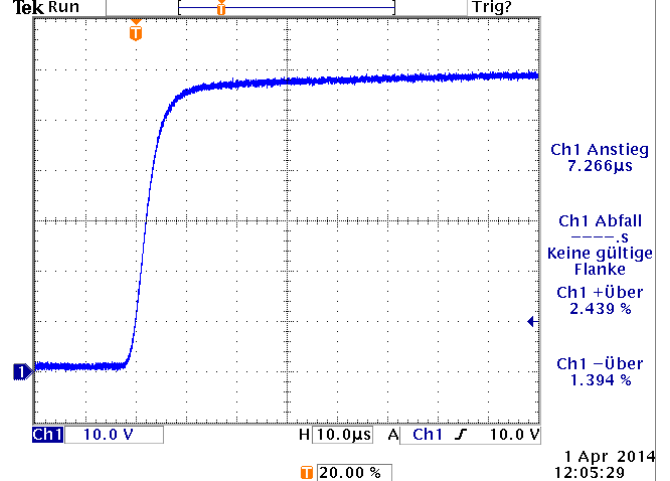

Measured rise-time 2.673ms

Measured rise-time 7.266µs

Comparison measurement 8:

**Abrupt voltage change from 59.3V/60V to 0V with a 10Ω load connected
(the minor proper solutions has a maximum voltage of 59.3V)**

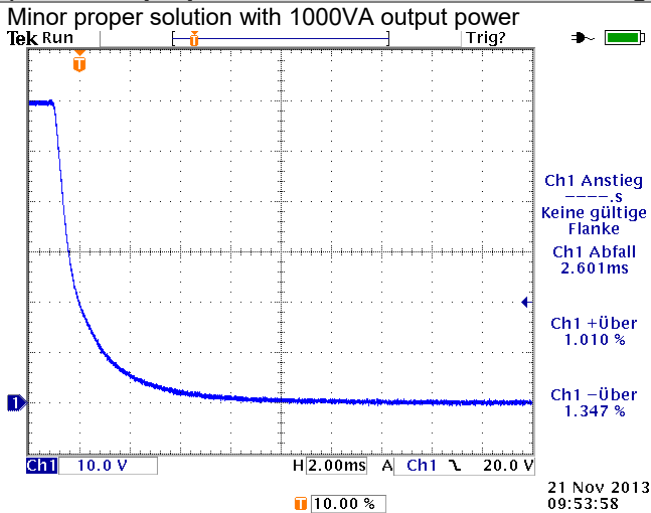

Measured fall-time 2.601ms

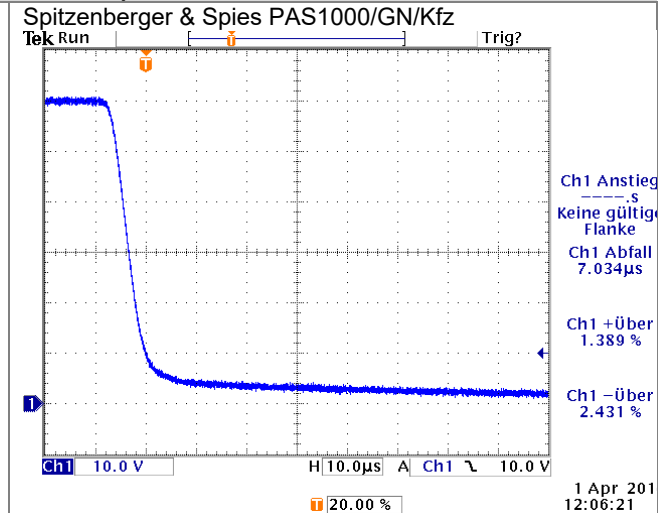

Measured fall-time 7.034μs

Comparison measurement 9:

**Abrupt voltage change from 0V to 59.3/60V and back to 0V with a 10Ω load connected
(the minor proper solutions has a maximum voltage of 59.3V)
at a time resolution of 20ms/DIV**

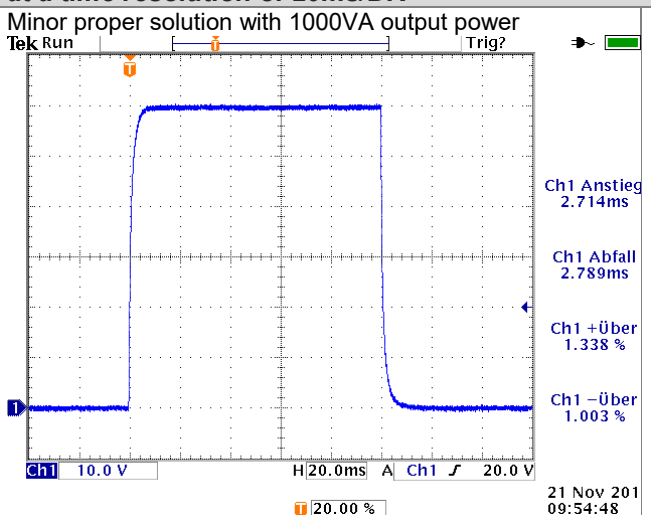

Measured rise-time 2.714ms
Measured fall-time 2.789ms

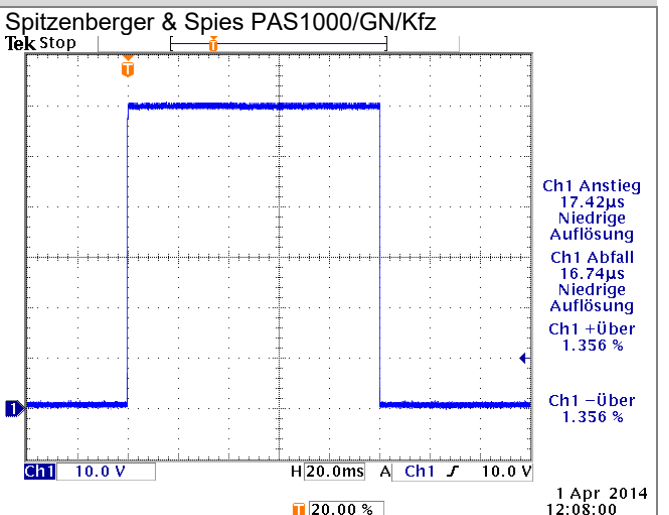

Measured rise-time 17.42μs
Measured fall-time 16.74μs