

Solid State Broadband High Power Amplifier

2198
20 - 6000 MHz 100/100/40 Watts

The 2198 is a tri-band amplifier housed in a single chassis and is suitable for high bandwidth, high power CW, modulated, and pulse applications. This amplifier utilizes both High power LDMOS and GaN devices that provide wide frequency response, high gain, high peak power capability, and low distortions. Exceptional performance, long-term reliability and high efficiency are achieved by employing advanced broadband RF matching networks and combining techniques, EMI/RFI filters, and all qualified components. The amplifier is constructed with a 3RU drawer, including the forced air-cooling. Available operating voltage configurations are single phase 100-240 VAC, up to 400Hz and 28 VDC. The amplifier comes standard with user selectable modes; Automatic Level Control (ALC) and Manual Gain Control (MGC).



SKU#: 2198-001

Each band overlaps and selection of the band is easy via the front panel touch screen or with a PC connected to the Ethernet port as a peer connection or networked. The amplifier includes a built-in control and monitoring system, with remote management and diagnostics via an embedded web server allowing network managed site status and control simply by connecting the unit's Ethernet port to a LAN. Using a web browser and the unit's IP address (IPV4) allows ease of access with the benefit of multi-level security. The control system core runs an embedded OS (Linux), has a built-in non-volatile memory for event recording, and factory setup recovery features. The extended memory option allows storage of control parameters and event logs.

Empower RF's ISO9001 Quality Assurance Program assures consistent performance and the highest reliability.

- Solid-state Class AB design
- Suitable for CW, AM, FM and pulse (Consult factory for other modulation types)
- Compact Modular design
- 50 ohm input/output impedance
- Built-in Control, Monitoring and Protection functions
- High reliability and ruggedness

ELECTRICAL SPECIFICATIONS 120V_{AC}, @ 25°C, 50 Ω System

Parameter	Symbol	Min	Typ	Max	Unit
Operating Frequency	Band A	20		1000	MHz
	Band B	1000		3000	
	Band C	2000		6000	
Power Output CW ^(Note 1)	P _{SAT}	100/100/40			Watt
Power Gain	G _P	49/49/45			dB
Input Power for Rated P _{SAT} , MGC Mode ^(Note 2)	P _{IN}	-5	0	+1.0	dBm
Input Power Range, ALC Mode	P _{IN-RANGE}	-5.0		+5.0	dBm
Small Signal Gain Flatness / Leveled ALC	ΔG			±3.5 / ±1.5	dB
Gain Adjustment Range	VVA	20			dB
Input Return Loss	S ₁₁			-10	dB
Noise Figure @ maximum gain	NF			15	dB
Third Order Intermodulation Distortion 2-Tone @ 44/44/40dBm per tone, 1MHz Spacing	IM3		-25		dBc
Harmonics @ Rated P _{OUT}	2 ND		-20	-10	dBc
	3 RD		-20	-10	
Spurious Signals	Spur			-60	dBc
Operating Voltage	V _{AC}	100	120	240	Volt
	V _{DC}	24	28	32	
Power Consumption @ Rated P _{OUT}	P _D			700	Watt
Band Switching Time	T _{SW}			60	mSec

Notes: 1. CW measurement performed in MGC Mode (Manual Gain Control). 2. Band C Input range -11 to 1dBm.

MECHANICAL SPECIFICATIONS

Parameter	Value	Unit
Dimensions W x H x D	19.0 x 5.25 x 23.7	Inch
Weight	50	Pound
RF Connectors Input/Output	Type-N, Female	
RF Sample	Type-SMA, Female	
Blanking Input	Type-BNC, Female	
Cooling	Built-in forced-air cooling system	

Solid State Broadband High Power Amplifier

2198
20 - 6000 MHz 100/100/40 Watts

ENVIRONMENTAL CHARACTERISTICS

Parameter	Symbol	Min	Typ	Max	Unit
Operating Ambient Temperature	T _A	-10		+50	°C
Non-operating Temperature	T _{STG}	-40		+85	°C
Relative Humidity (non-condensing)	RH			95	%
Shock / Vibration - MIL-STD-810F Shock Method 516.5, Vibration Method 514.5	SH / VI				

PROTECTIONS:

Parameter	Specification	Unit
Input Overdrive	+10 dBm	Max
VSWR Protection	At 3:1 – PA backs-off output power to a safe operating level – no system shutdown, “On Air” time is maximized	-
Thermal – Graceful Degradation	Ambient 50°C	Min
Default Data Recovery	Factory Default Calibration Recovery	

COMMUNICATION INTERFACES:

Function	Utility	Connector
Ethernet	Network management of device / web interface	RJ45
USB	Mass storage / Expansion Bus	USB 1.x/2.0 compatible
RS-232 (default) Or RS-422 (optional)	Serial management of device / local operator access	D-Sub 9-position Male

SYSTEM I/O INTERFACE – 14-Position

Pin #	Description	Specification
1	N/C	No Connection (reserved)
2	N/C	No Connection (reserved)
3	Summary Fault	Summary Fault: Active TTL Logic Low ($\leq 0.7V$), (<i>Internally Pulled-High</i>)
4	N/C	No Connection (reserved)
5	Shutdown	Amplifier Disable: TTL Logic Low ($\leq 0.7V$), (<i>Internally Pulled-High</i>)
6	AUX P/S Test Point	+12.0V _{DC} $\pm 2.0V$ (resettable 0.5amp fuse)
7	Main P/S Test Point	+44.0V _{DC} $\pm 4.8V$ (resettable 0.5amp fuse)
8	GND	Ground
9-11	Open drain control	Site management utility (reserved)
12&13	Digital I/O (configurable)	Site management utility (reserved)
14	GND	Ground

AVAILABLE OPTIONS

2198-XXX

- 001 100-240VAC, 1-phase, 47-63 Hz, Rear RF Connectors
- 002 28 VDC, Rear RF Connectors
- 003 100-240VAC, 1-phase, 47-63 Hz, Front RF Connectors
- 004 28 VDC, Front RF Connectors

Standard Feature:

- LCD Control, Ethernet & Serial Comm
- Main RF Connectors: **Input & Output** [Type-N, F]
- Sample Port: SMA-F [Forward & Reverse]
- Blanking/Gating Port: BNC-F
- Rack Slides, Handles and Rackmount Brackets

NOTIONAL BLOCK DIAGRAM

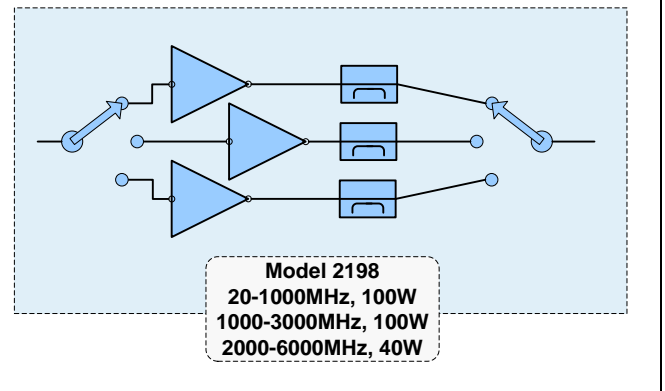

Solid State Broadband High Power Amplifier

2198

20 - 6000 MHz 100/100/40 Watts

OUTLINE DRAWING – (shown with Rear RF Connectors)

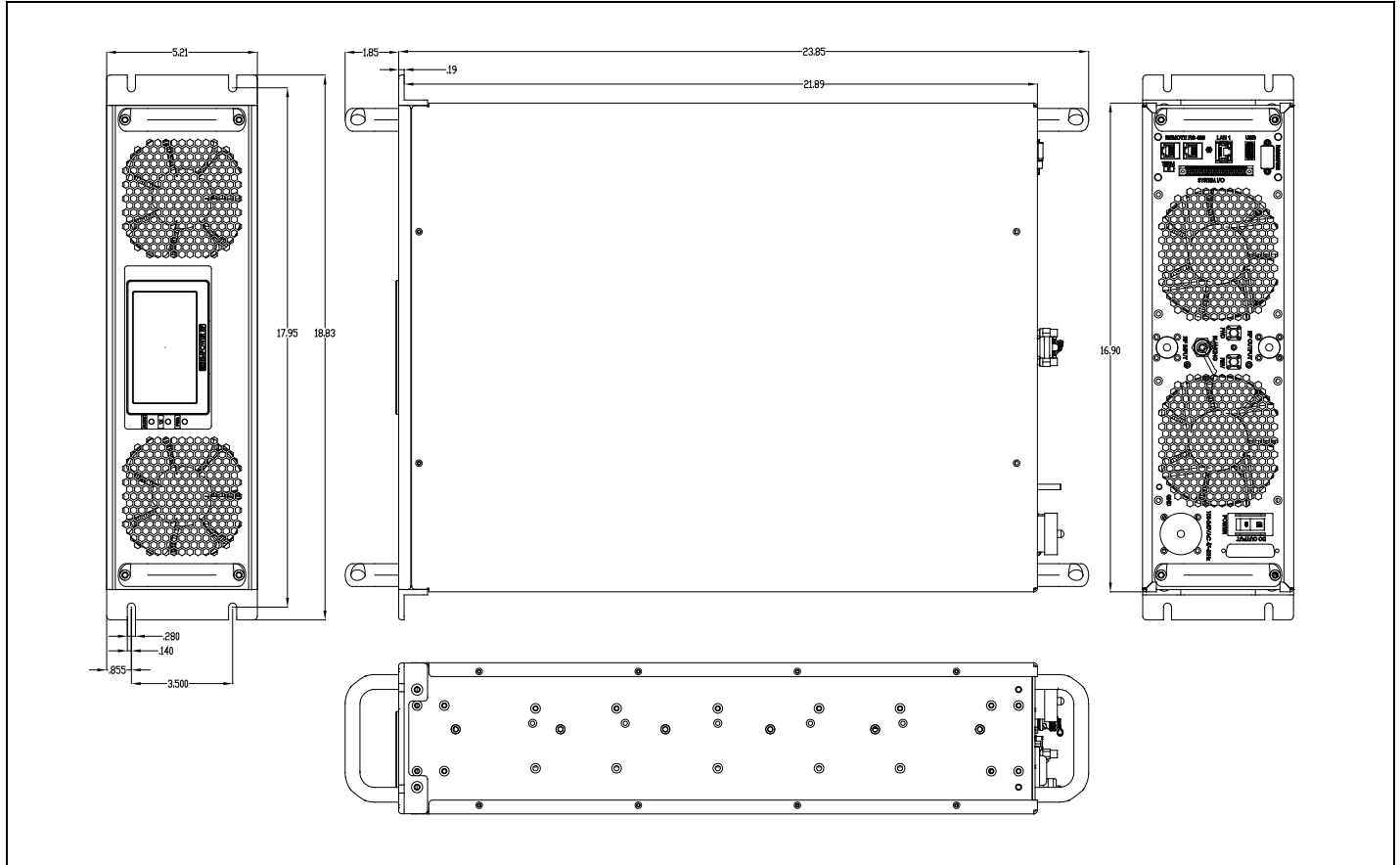

Front and Rear Views

